

Neousys Technology Inc.

Nuvo-9531 Series

Nuvo-9531-FT Series

User Manual

Revision 1.4

Table of Contents

Table of Contents	2
Legal Information	5
Contact Information	6
Declaration of Conformity	6
Copyright Notice	7
Safety Precautions.....	8
Hot Surface Warning.....	8
Battery Warning.....	8
Service and Maintenance	9
ESD Precautions	9
Restricted Access Location	9
About This Manual	10

1 Introduction

1.1 Product Specifications.....	12
1.1.1 Nuvo-9531 Specifications	12
1.1.2 Nuvo-9531-FT Specifications	15
1.2 Dimension	17
1.2.1 Top View of Nuvo-9531 Series.....	17
1.2.2 Front View of Nuvo-9531 Series	17
1.2.3 Back View of Nuvo-9531 Series.....	18
1.2.4 Side View of Nuvo-9531 Series	18
1.2.5 Top View of Nuvo-9531-FT Series	19
1.2.6 Front View of Nuvo-9531-FT Series.....	19
1.2.7 Back View of Nuvo-9531-FT Series	20
1.2.8 Side View of Nuvo-9531-FT Series.....	20
1.3 Dimension with Fan Kit.....	21
1.3.1 Top View of Nuvo-9531 Series with Fan Kit.....	21
1.3.2 Front View of Nuvo-9531 Series with Fan Kit.....	22
1.3.3 Back View of Nuvo-9531 Series with Fan Kit	22
1.3.4 Side View of Nuvo-9531 Series with Fan Kit.....	23

2 System Overview

2.1 Nuvo-9531 Series Packing List	24
2.1 Nuvo-9531-FT Series Packing List.....	24
2.2 Front Panel I/O	25
2.3.1 Power Button	26
2.3.2 System Status LED	26
2.3.3 Reset Button	27
2.3.4 2.5G Ethernet Port (Optional PoE+)	27
2.3.5 DisplayPort	28
2.3.6 USB3.2 Gen1 Ports	29
2.3.7 CMOS Reset Button	29
2.3.8 2.5" HDD/ SSD Hot-swappable Tray.....	30
2.2 Rear Panel I/O	31
2.4.1 3-pin DC Input with Remote On/ Off (Optional Ignition Power Control).....	32
2.4.2 USB2.0 Ports	32
2.4.3 COM2/3/4 Port	33
2.4.4 COM1 Port.....	34
2.4.5 VGA Port.....	35
2.4.6 4-Pole 3.5mm Microphone-in/ Speaker-out Jack	35
2.4.7 DIO Port Pin Definition & Wiring	36
2.5 Internal I/O Functions.....	39
2.5.1 M.2 2280 Slot for SSD (PCIe Gen4 x4)	39
2.5.2 Single DRAM SO-DIMM Slot	41
2.5.3 mini-PCIe Slot.....	42
2.5.4 Ignition Rotary Switch	44

2.5.5	SATA Port.....	45
2.5.6	M.2 2230 E Key Slot	46
2.5.7	On/ Off Ctrl & Status Output.....	48

3 System Installation

3.1	Disassembling Nuvo-9531	50
3.2	Disassembling Nuvo-9531-FT	53
3.3	Installing Internal Components	57
3.3.1	CPU Installation for Barebone System.....	57
3.3.2	Remove the Replace the Existing CPU	63
3.3.3	DDR4 SO-DIMM Installation	70
3.3.4	M.2 2280 SSD Installation.....	73
3.3.5	mini-PCIe Module Installation	75
3.3.6	M.2 2230 E Key Module Installation.....	78
3.3.7	External Hot-swappable 2.5" HDD/ SSD Installation.....	80
3.4	Installing Nuvo-9531's Enclosure.....	83
3.5	Installing Nuvo-9531-FT's Enclosure	85
3.6	Ethernet/ PoE+ Port Panel Screw Fix	88
3.7	FAN Kit Installation (Nuvo-9531 only).....	89
3.8	Mounting Nuvo-9531 Series	92
3.8.1	Wall-mounting Nuvo-9531 Series	92
3.8.2	Installing DIN-Rail Mounting Kit (Optional).....	93
3.9	Installing Nuvo-9531-FT Series	94
3.10	Wall-mounting Nuvo-9531-FT Series (Optional)	95
3.11	Powering On the System	96
3.11.1	Powering On Using the Power Button.....	96
3.11.2	Powering On Using External Non-latched Switch (Remote On/ Off).....	97
3.11.3	Powering On Using Wake-on-LAN.....	98
3.11.4	System Always On.....	100
3.12	Ignition Power Control (Optional)	101
3.12.1	Principles of Ignition Power Control	101
3.12.2	Additional Features of Ignition Power Control	102
3.12.3	Wiring Ignition Signal	103
3.12.4	Configure your Windows system.....	104
3.12.5	Operation Modes of Ignition Power Control	105

4 System Configuration

4.1	BIOS Settings	107
4.1.1	COM1 Configuration	108
4.1.2	COM Port Slew Rate.....	109
4.1.3	COM Port High Speed Mode	110
4.1.4	COM2/3/4 Port Configuration.....	111
4.1.5	TPM Availability.....	112
4.1.6	Power over Ethernet (PoE) Power Enable (Optional)	113
4.1.7	Power On After Power Failure Option	115
4.1.8	Power & Performance (CPU SKU Power Configuration)	116
4.1.9	Wake on LAN Option	117
4.1.10	Boot Menu	118
4.1.11	Add Boot Options (Position New Boot Device)	120
4.1.12	Watchdog Timer for Booting.....	121

5 OS Support and Driver Installation

5.1	Operating System Compatibility	122
5.2	Driver Installation	123
5.2.1	Install Drivers Automatically	123

Appendix A Using WDT & DIO

Watchdog Timer	124
-----------------------------	------------

Installing WDT_DIO Library	124
WDT and DIO Library Installation	125
WDT Functions	127
InitWDT	127
SetWDT	127
StartWDT	128
ResetWDT	128
StopWDT	128
DIO Functions.....	129
InitDIO	129
DIReadLine	129
DIReadPort	129
DOWriteLine.....	130
DOWritePort.....	130

Appendix B PoE On/ Off Control

GetStatusPoEPort	131
EnablePoEPort	132
DisablePoEPort	133

Legal Information

All Neosys Technology Inc. products shall be subject to the latest Standard Warranty Policy

Neosys Technology Inc. may modify, update or upgrade the software, firmware or any accompanying user documentation without any prior notice. Neosys Technology Inc. will provide access to these new software, firmware or documentation releases from download sections of our website or through our service partners.

Before installing any software, applications or components provided by a third party, customer should ensure that they are compatible and interoperable with Neosys Technology Inc. product by checking in advance with Neosys Technology Inc.. Customer is solely responsible for ensuring the compatibility and interoperability of the third party's products. Customer is further solely responsible for ensuring its systems, software, and data are adequately backed up as a precaution against possible failures, alternation, or loss.

For questions in regards to hardware/ software compatibility, customers should contact Neosys Technology Inc. sales representative or technical support.

To the extent permitted by applicable laws, Neosys Technology Inc. shall NOT be responsible for any interoperability or compatibility issues that may arise when (1) products, software, or options not certified and supported; (2) configurations not certified and supported are used; (3) parts intended for one system is installed in another system of different make or model.

Contact Information

For our contact information, please visit our [official website](#).

Declaration of Conformity

FCC

This equipment has been tested and found to comply with the limits for a Class A digital device, pursuant to part 15 of the FCC Rules. These limits are designed to provide reasonable protection against harmful interference when the equipment is operated in a commercial environment. This equipment generates, uses, and can radiate radio frequency energy and, if not installed and used in accordance with the instruction manual, may cause harmful interference to radio communications. Operation of this equipment in a residential area is likely to cause harmful interference in which case the user will be required to correct the interference at own expense.

CE

The product(s) described in this manual complies with all applicable European Union (CE) directives if it has a CE marking. For computer systems to remain CE compliant, only CE-compliant parts may be used. Maintaining CE compliance also requires proper cable and cabling techniques.

Copyright Notice

All rights reserved. This publication may not be reproduced, transmitted, transcribed, stored in a retrieval system, or translated into any language or computer language, in any form or by any means, electronic, mechanical, magnetic, optical, chemical, manual or otherwise, without the prior written consent of Neosys Technology, Inc.

Disclaimer

This manual is intended to be used as an informative guide only and is subject to change without prior notice. It does not represent commitment from Neosys Technology Inc. Neosys Technology Inc. shall not be liable for any direct, indirect, special, incidental, or consequential damages arising from the use of the product or documentation, nor for any infringement on third party rights.

Patents and Trademarks

Neosys, the Neosys logo, Expansion Cassette, MezIO™ are registered patents and trademarks of Neosys Technology, Inc.

Windows is a registered trademark of Microsoft Corporation.

Intel®, Core™ are registered trademarks of Intel Corporation

NVIDIA®, GeForce® are registered trademarks of NVIDIA Corporation

All other names, brands, products or services are trademarks or registered trademarks of their respective owners.

Safety Precautions

Read these instructions carefully before you install, operate, or transport the system.

- Install the system or DIN rail associated with, at a sturdy location
- Install the power socket outlet near the system where it is easily accessible
- Secure each system module(s) using its retaining screws
- Place power cords and other connection cables away from foot traffic. Do not place items over power cords and make sure they do not rest against data cables
- Shutdown, disconnect all cables from the system and ground yourself before touching internal modules
- Ensure that the correct power range is being used before powering the device
- Should a module fail, arrange for a replacement as soon as possible to minimize down-time
- By means of a power cord connected to a socket-outlet with earthing connection
- This product is intended to be supplied by a Listed Power Adapter or DC power source, rated 8-48V, 16A, Tma 60 degree C and 5000m altitude during operation. If further assistance is required, please contact Neousys Technology
- If the system is not going to be used for a long time, disconnect it from mains (power socket) to avoid transient over-voltage

Hot Surface Warning



HOT SURFACE. DO NOT

TOUCH. "ATTENTION: Surface chaude. Ne pas toucher."

WARNING!

Components/ parts inside the equipment may be hot to touch!

Please wait one-half hour after switching off before handling parts.

Battery Warning

Caution!



- Batteries are at risk of exploding if incorrectly installed
- Do not attempt to recharge, force open, or heat the battery
- Replace the battery only with the same or equivalent type recommended by the manufacturer

Service and Maintenance

- ONLY qualified personnel should service the system
- Shutdown the system, disconnect the power cord and all other connections before servicing the system
- When replacing/ installing additional components (expansion card, memory module, etc.), insert them as gently as possible while assuring proper connector engagement

ESD Precautions

- Handle add-on module, motherboard by their retention screws or the module's frame/ heat sink. Avoid touching the PCB circuit board or add-on module connector pins
- Use a grounded wrist strap and an anti-static work pad to discharge static electricity when installing or maintaining the system
- Avoid dust, debris, carpets, plastic, vinyl and styrofoam in your work area
- Do not remove any module or component from its anti-static bag before installation

Restricted Access Location

The controller is intended for installation only in certain environments where both of the following conditions apply:

- Access can only be gained by **QUALIFIED SERVICE PERSONNEL** who have been instructed on the reasons for restrictions applied to the location and any precautions that shall be taken
- Access is through the use of a **TOOL**, lock and key, or other means of security, and is controlled by the authority responsible for the location

About This Manual

This guide introduces Neousys Nuvo-9531/ Nuvo-9531-FT series systems. They are compact fanless embedded computers with Intel® 14th/ 13th /12th Gen Core™ i9/ i7/ i5/ i3 processor up to 24 cores and 32 threads.

The guide also demonstrates the system's basic installation procedures.

Revision History

Version	Date	Description
1.0	May. 2023	Initial release
1.1	Jul. 2023	Updated DIO wiring diagram
1.2	Jun. 2024	Added Nuvo-9531-FT series Updated Nuvo-9531 fan kit installation
1.3	Feb. 2025	Updated Nuvo-9531-FT installation
1.4	Nov. 2025	Added support for Intel® 14 th Gen processors

1 Introduction

Nuvo-9531 is one of the most compact fanless embedded computers based on the Intel 14th/ 13th/ 12th-Gen platform. Measuring just 212 x 165 x 63 mm, it can fit into restricted spaces, such as in robotic arm and AMR applications. Despite its compact size, Nuvo-9531 does not compromise on performance. Built on the advanced Intel 7 process, Intel 13th Gen processors have up to 24 cores/ 32 threads to deliver up to 2x the performance when compared to previous Intel 10th or 11th Gen platforms. Nuvo-9531 is a compact fanless embedded computer that offers the ultimate computing for various industrial applications



Nuvo-9531 has rich I/O functions. It features four 2.5GbE with optional PoE+ PSE and four USB3.2 Gen1 ports for multiple camera connectivity for machine vision and surveillance applications. In addition, it features a Gen4 x4 M.2 NVMe slot for the latest NVMe SSDs that supports read/ write speeds up to 7000 MB/s; a hot-swappable HDD tray to hot-swap the storage drive without turning off the system or dismantling the chassis; two mPCIe and one M.2 E key slots to install WiFi or 5G/ 4G wireless communication modules. The system is also equipped with 8x DIO, 2x COM ports, and dual display outputs for your industrial embedded application needs.



As a compact embedded computer, Nuvo-9531 delivers excellent computing performance and offers an abundance of I/O connections. It is suitable for a variety of industrial applications, especially when installation space is limited.

1.1 Product Specifications

1.1.1 Nuvo-9531 Specifications

System Core	
Processor	<p>Supports Intel® 14th-Gen CPU (LGA1700 socket, 65W/ 35W TDP)</p> <ul style="list-style-type: none"> - Intel® Core™ i9-14900/ i9-14900T - Intel® Core™ i7-14700/ i7-14700T - Intel® Core™ i5-14500/ i5-14400/ i5-14500T - Intel® Core™ i3-14100/ i3-14100T <p>Supports Intel® 13th-Gen CPU (LGA1700 socket, 65W/ 35W TDP)</p> <ul style="list-style-type: none"> - Intel® Core™ i9-13900E/ i9-13900TE - Intel® Core™ i7-13700E/ i7-13700TE - Intel® Core™ i5-13500E/ i5-13400E/ i5-13500TE - Intel® Core™ i3-13100E/ i3-13100TE <p>Supports Intel® 12th-Gen CPU (LGA1700 socket, 35W/ 65W TDP)</p> <ul style="list-style-type: none"> - Intel® Core™ i9-12900E/ i9-12900TE - Intel® Core™ i7-12700E/ i7-12700TE - Intel® Core™ i5-12500E/ i5-12500TE - Intel® Core™ i3-12100E/ i3-12100TE - Intel® Pentium® G7400E/ G7400TE - Intel® Celeron® G6900E/ G6900TE
Chipset	Intel® H610E platform controller hub
Graphics	Integrated Intel® UHD Graphics 770 (32EU)/ 730 (24EU)
Memory	Up to 32 GB non-ECC DDR4 3200 (one SODIMM slot)
TPM	Supports dTPM2.0
I/O Interface	
Ethernet	4x 2.5GBASE-T Ethernet ports by Intel® I226-IT GbE controller
Optional PoE+	Optional IEEE 802.3at PoE+ PSE for 4x2.5GbE ports 100 W total power budget
USB	4x USB 3.2 Gen1 (5 Gbps) ports 2x USB 2.0 ports
Video Port (Integrated Graphics)	1x VGA output, supporting 1920 x 1200 resolution 1x DisplayPort, supporting 4096 x 2304 resolution
Serial Port	1x software-programmable RS-232/422/485 ports (COM1)

	3x 3-wire RS-232 ports (COM2/3/4) or 1x RS-422/485 port (COM2)
Audio	1x 3.5 mm jack for mic-in and speaker-out
Isolated DIO	4-CH isolated DI and 4-CH isolated DO
Storage Interface	
SATA HDD	1x hot-swappable 2.5" HDD/ SSD tray
M.2	1x M.2 2280 M key socket (PCIe Gen4 x4) for NVMe SSD
Internal Expansion Bus	
Mini PCI Express	2x full-size mini PCI Express sockets with internal SIM sockets
M.2 E Key	1x M.2 2230 E key socket for WiFi5, WiFi6 or Google edge TPU module
Power Supply	
DC Input	1x 3-pin pluggable terminal block for 8-48V DC input with optional ignition power control
Power Consumption	With i7-12700 (65W mode): 141.4W (Max.) @ 24V With i7-12700 (65W mode): 146.4W (Max.) @ 48V With i7-12700TE (35W mode): 106.6W (Max.) @ 24V With i7-12700TE (35W mode): 111.8W (Max.) @ 48V With i5-12400 (35W mode): 105.1W (Max.) @ 24V With i5-12400 (35W mode): 110.9W (Max.) @ 48V With i5-12400 (65W mode): 120.5W (Max.) @ 24V With i5-12400 (65W mode): 126.2W (Max.) @ 48V
Mechanical	
Dimension	212mm (W) x 165 mm (D) x 63 mm (H)
Weight	2.5 kg
Mounting	Wall-mount mounting bracket or optional DIN-Rail mounting
Environmental	
Operating Temperature	With 35W CPU -25°C to 60°C */** With 65W CPU, optional fan kit is required -25°C to 60°C */**
Storage Temperature	-40°C to 85°C
Humidity	10%~90% , non-condensing
Vibration	Operating, MIL-STD-810G, Method 514.6, Category 4
Shock	Operating, MIL-STD-810G, Method 516.6, Procedure I, Table 516.6-II
EMC	CE/FCC Class A, according to EN 55032 & EN 55035

* For sub-zero operating temperature, a wide temperature HDD or Solid State Disk (SSD) is

required.

*** For i7 CPUs, thermal throttling may occur when sustained full-loading applied at 60°C ambient temperature.*

1.1.2 Nuvo-9531-FT Specifications

System Core	
Processor	<p>Supports Intel® 14th-Gen CPU (LGA1700 socket, 65W/ 35W TDP)</p> <ul style="list-style-type: none"> - Intel® Core™ i9-14900/ i9-14900T - Intel® Core™ i7-14700/ i7-14700T - Intel® Core™ i5-14500/ i5-14400/ i5-14500T - Intel® Core™ i3-14100/ i3-14100T <p>Supports Intel® 13th-Gen CPU (LGA1700 socket, 65W/ 35W TDP)</p> <ul style="list-style-type: none"> - Intel® Core™ i9-13900E/ i9-13900TE - Intel® Core™ i7-13700E/ i7-13700TE - Intel® Core™ i5-13500E/ i5-13400E/ i5-13500TE - Intel® Core™ i3-13100E/ i3-13100TE <p>Supports Intel® 12th-Gen CPU (LGA1700 socket, 35W/ 65W TDP)</p> <ul style="list-style-type: none"> - Intel® Core™ i9-12900E/ i9-12900TE - Intel® Core™ i7-12700E/ i7-12700TE - Intel® Core™ i5-12500E/ i5-12500TE - Intel® Core™ i3-12100E/ i3-12100TE - Intel® Pentium® G7400E/ G7400TE - Intel® Celeron® G6900E/ G6900TE
Chipset	Intel® H610E platform controller hub
Graphics	Integrated Intel® UHD Graphics 770 (32EU)/ 730 (24EU)
Memory	Up to 32 GB non-ECC DDR4 3200 (one SODIMM slot)
TPM	Supports dTPM2.0
I/O Interface	
Ethernet	4x 2.5GBASE-T Ethernet ports by Intel® I226-IT GbE controller
Optional PoE+	Optional IEEE 802.3at PoE+ PSE for 4x2.5GbE ports 100 W total power budget
USB	4x USB 3.2 Gen1 (5 Gbps) ports 2x USB 2.0 ports
Video Port (Integrated Graphics)	1x VGA output, supporting 1920 x 1200 resolution 1x DisplayPort, supporting 4096 x 2304 resolution
Serial Port	1x software-programmable RS-232/422/485 ports (COM1) 3x 3-wire RS-232 ports (COM2/3/4) or 1x RS-422/485 port (COM2)
Audio	1x 3.5 mm jack for mic-in and speaker-out

Isolated DIO	4-CH isolated DI and 4-CH isolated DO
Storage Interface	
SATA HDD	1x hot-swappable 2.5" HDD/ SSD tray
M.2	1x M.2 2280 M key socket (PCIe Gen4 x4) for NVMe SSD
Internal Expansion Bus	
Mini PCI Express	2x full-size mini PCI Express sockets with internal SIM sockets
M.2 E Key	1x M.2 2230 E key socket for WiFi5, WiFi6 or Google edge TPU module
Power Supply	
DC Input	1x 3-pin pluggable terminal block for 8-48V DC input with optional ignition power control
Power Consumption	With i7-12700 (65W mode): 141.4W (Max.) @ 24V With i7-12700 (65W mode): 146.4W (Max.) @ 48V With i7-12700TE (35W mode): 106.6W (Max.) @ 24V With i7-12700TE (35W mode): 111.8W (Max.) @ 48V With i5-12400 (35W mode): 105.1W (Max.) @ 24V With i5-12400 (35W mode): 110.9W (Max.) @ 48V With i5-12400 (65W mode): 120.5W (Max.) @ 24V With i5-12400 (65W mode): 126.2W (Max.) @ 48V
Mechanical	
Dimension	212mm (W) x 165 mm (D) x 45 mm (H)
Weight	2.4 kg
Mounting	Optional wall-mount bracket
Environmental	
Operating Temperature	With 35W CPU -25°C to 60°C */** With 65W CPU, configured in 35W TDP mode -25°C to 60°C */**
Storage Temperature	-40°C to 85°C
Humidity	10%~90%, non-condensing
Vibration	Operating, MIL-STD-810G, Method 514.6, Category 4
Shock	Operating, MIL-STD-810G, Method 516.6, Procedure I, Table 516.6-II
EMC	CE/FCC Class A, according to EN 55032 & EN 55035

* For sub-zero operating temperature, a wide temperature HDD or Solid State Disk (SSD) is required.

** The system was tested while mounted on an aluminum panel measuring 60(W) x 60(D) x 0.3(H) cm in a high temperature environment to simulate in-cabinet conditions.

1.2 Dimension



NOTE

All measurements are in millimeters (mm).

1.2.1 Top View of Nuvo-9531 Series

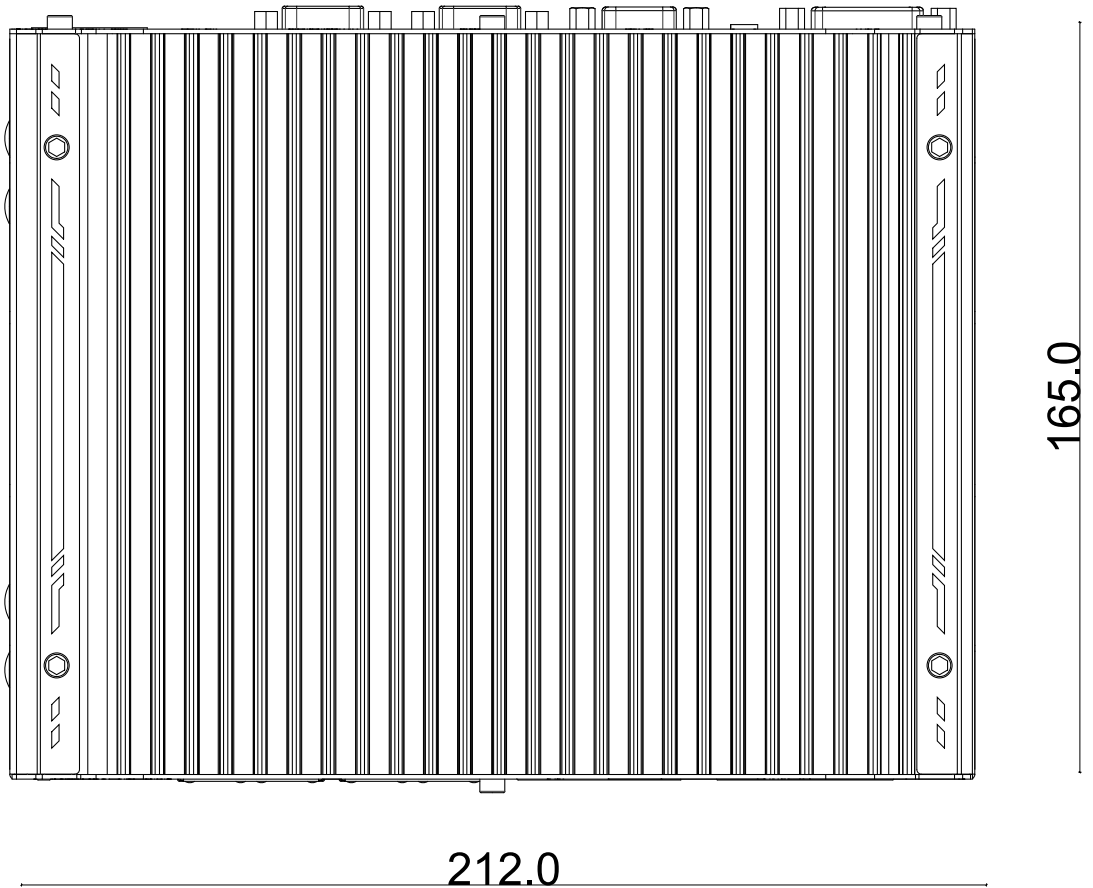

1.2.2 Front View of Nuvo-9531 Series

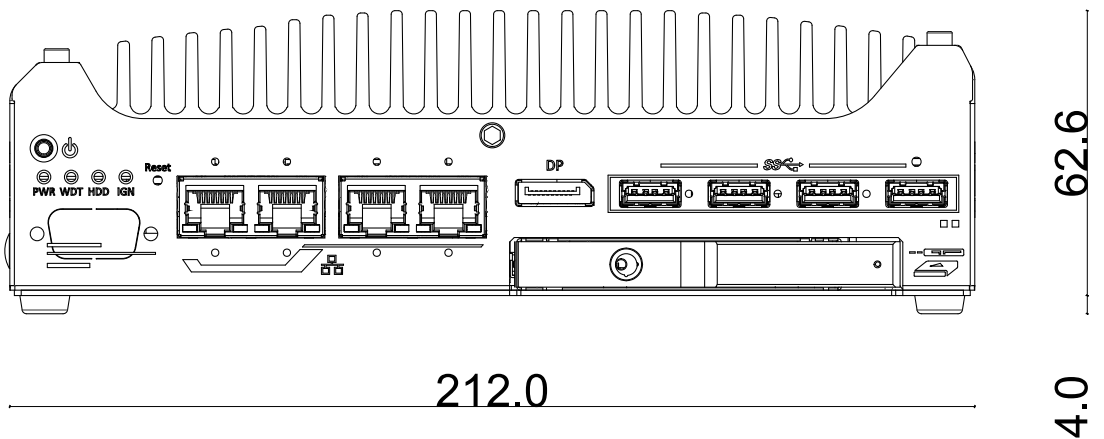

1.2.3 Back View of Nuvo-9531 Series

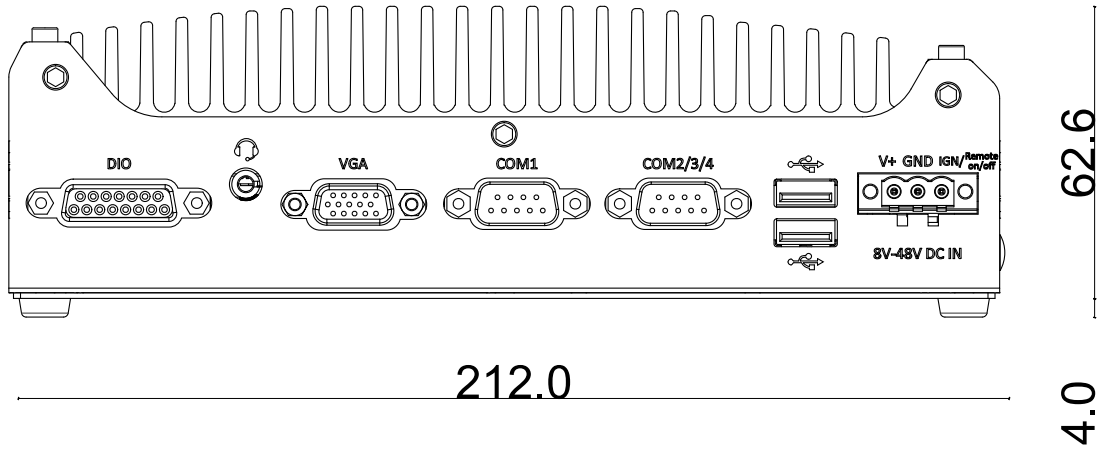

1.2.4 Side View of Nuvo-9531 Series

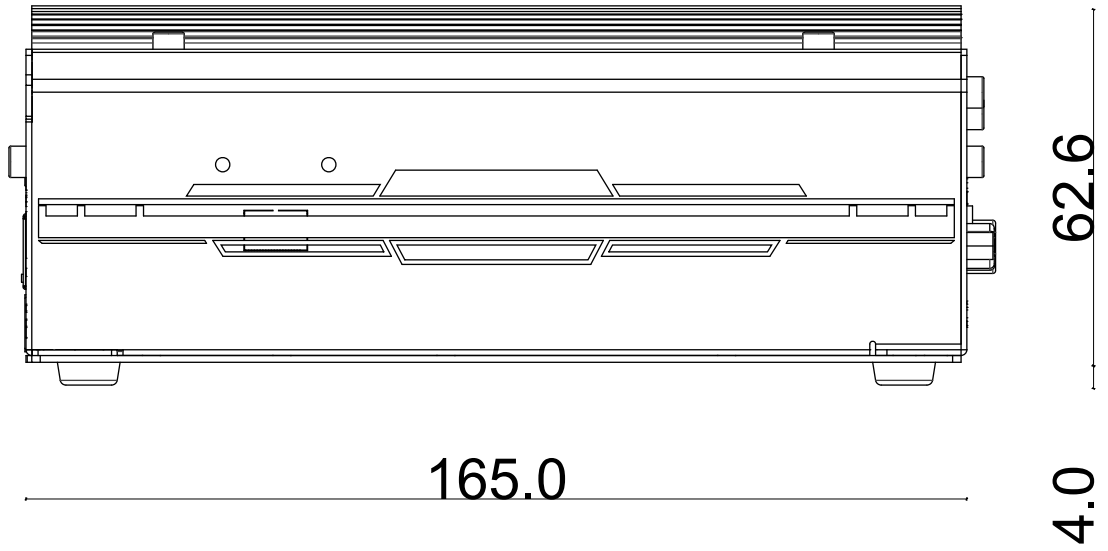

1.2.5 Top View of Nuvo-9531-FT Series

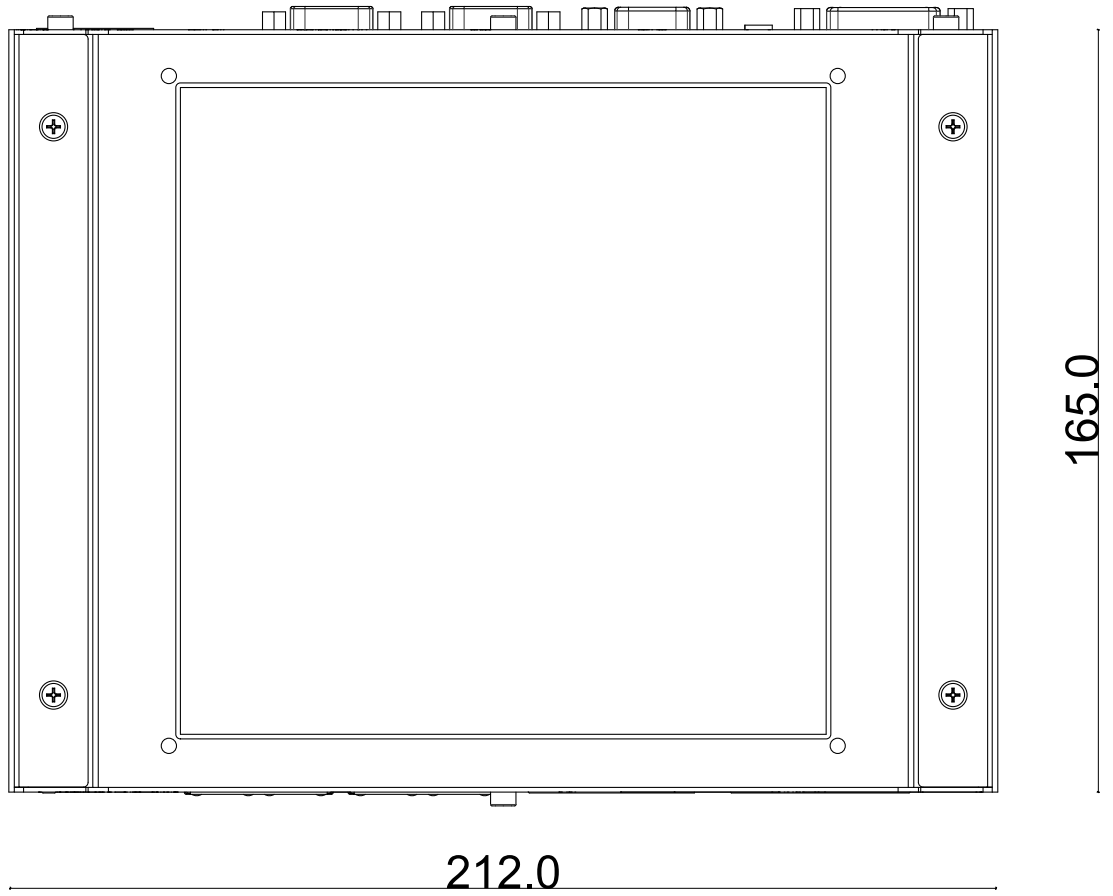

1.2.6 Front View of Nuvo-9531-FT Series

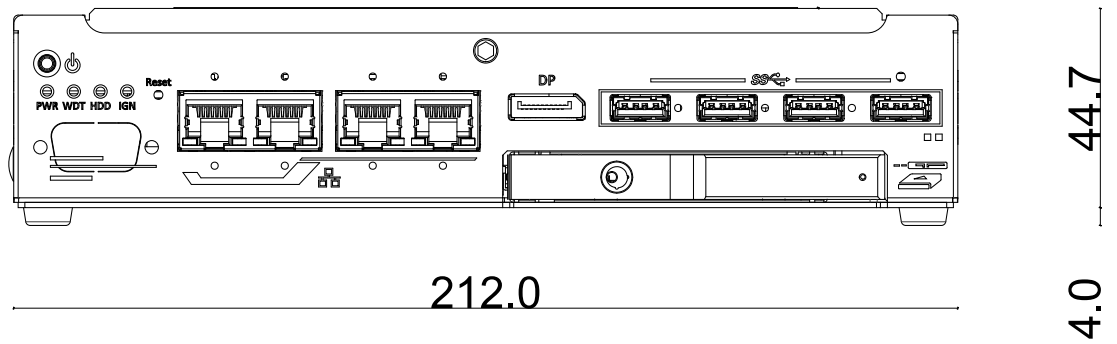

1.2.7 Back View of Nuvo-9531-FT Series

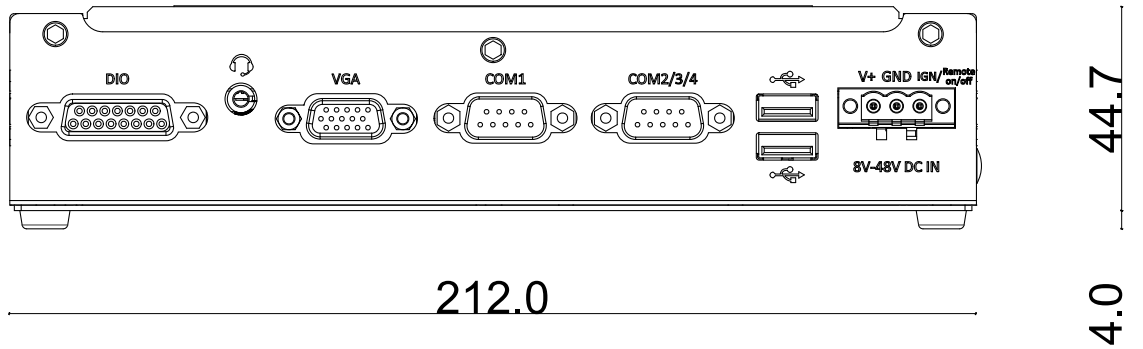

1.2.8 Side View of Nuvo-9531-FT Series

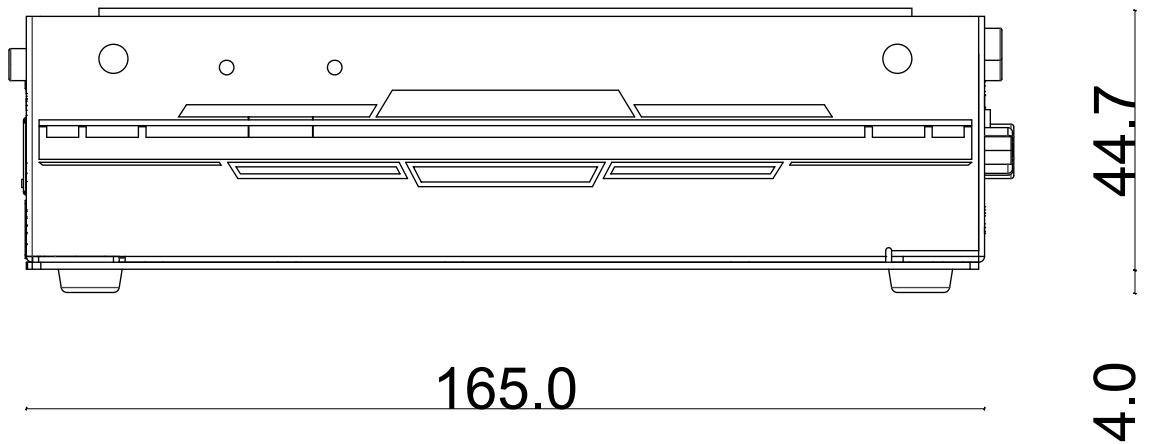

1.3 Dimension with Fan Kit

The fan kit is available for users when a 65W CPU is installed in the system.



NOTE

All measurements are in millimeters (mm).

1.3.1 Top View of Nuvo-9531 Series with Fan Kit

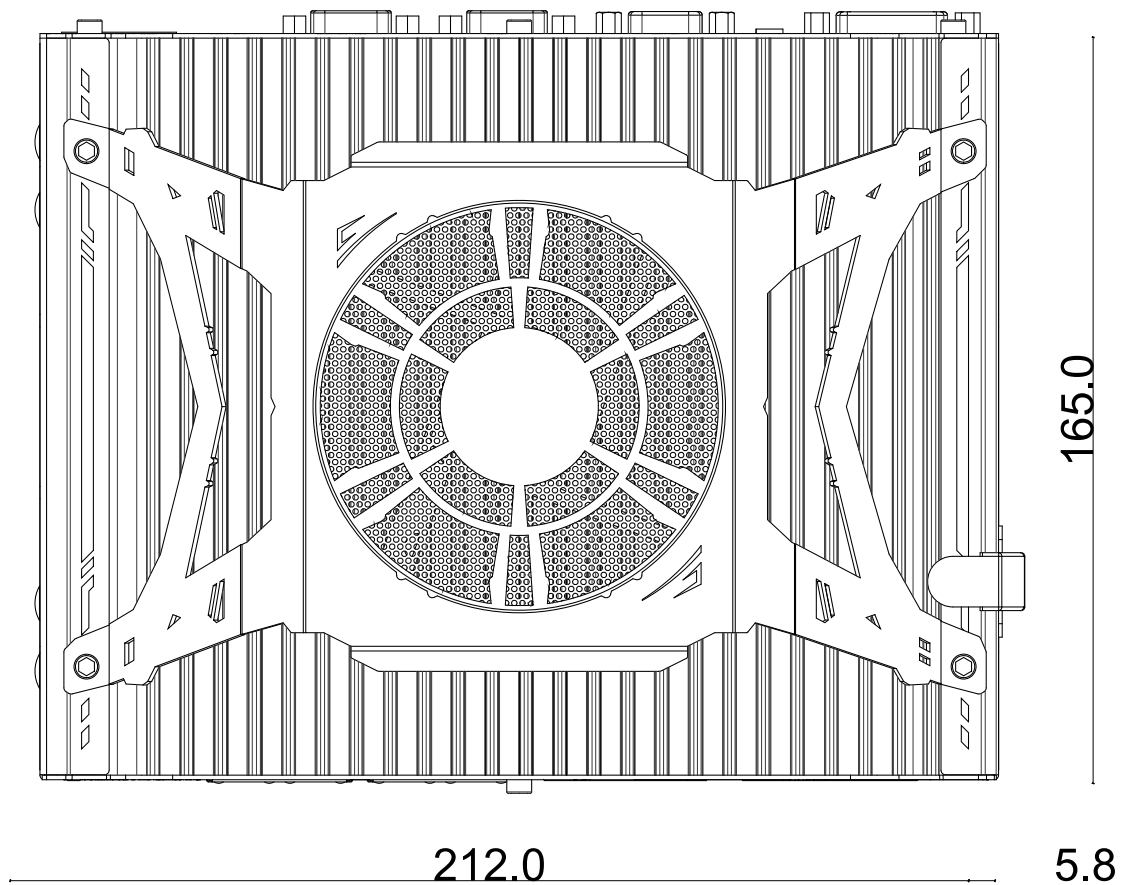

1.3.2 Front View of Nuvo-9531 Series with Fan Kit

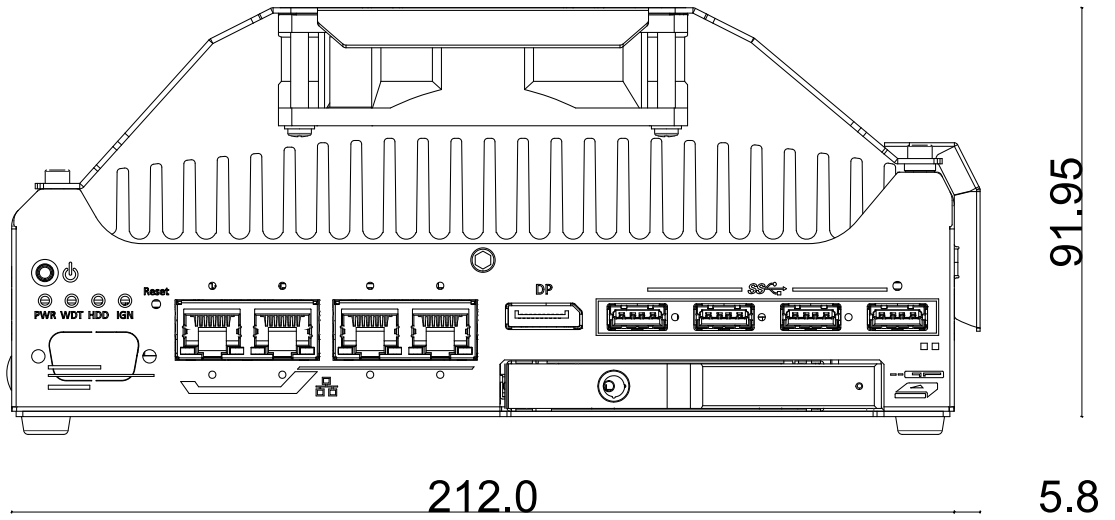

1.3.3 Back View of Nuvo-9531 Series with Fan Kit

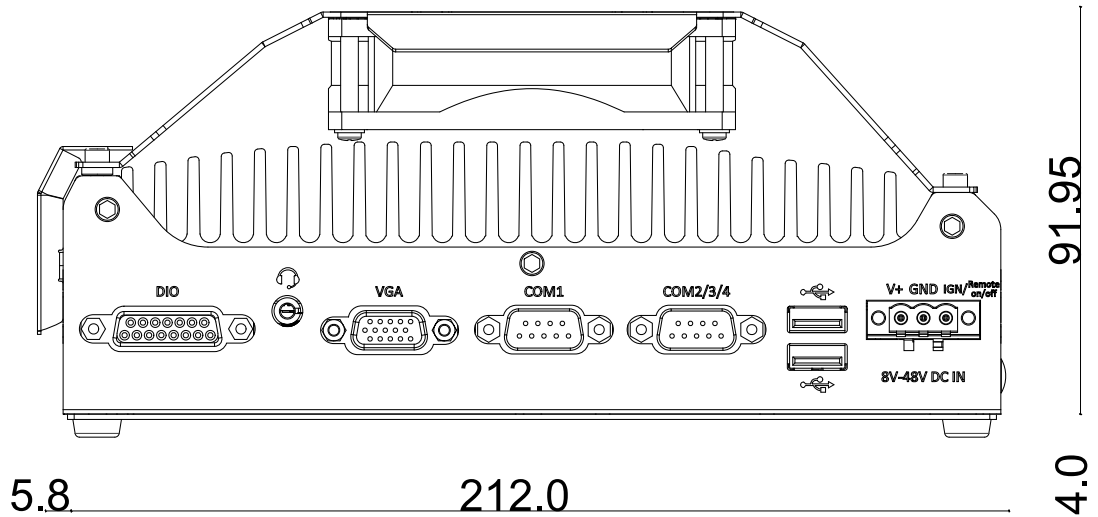

1.3.4 Side View of Nuvo-9531 Series with Fan Kit

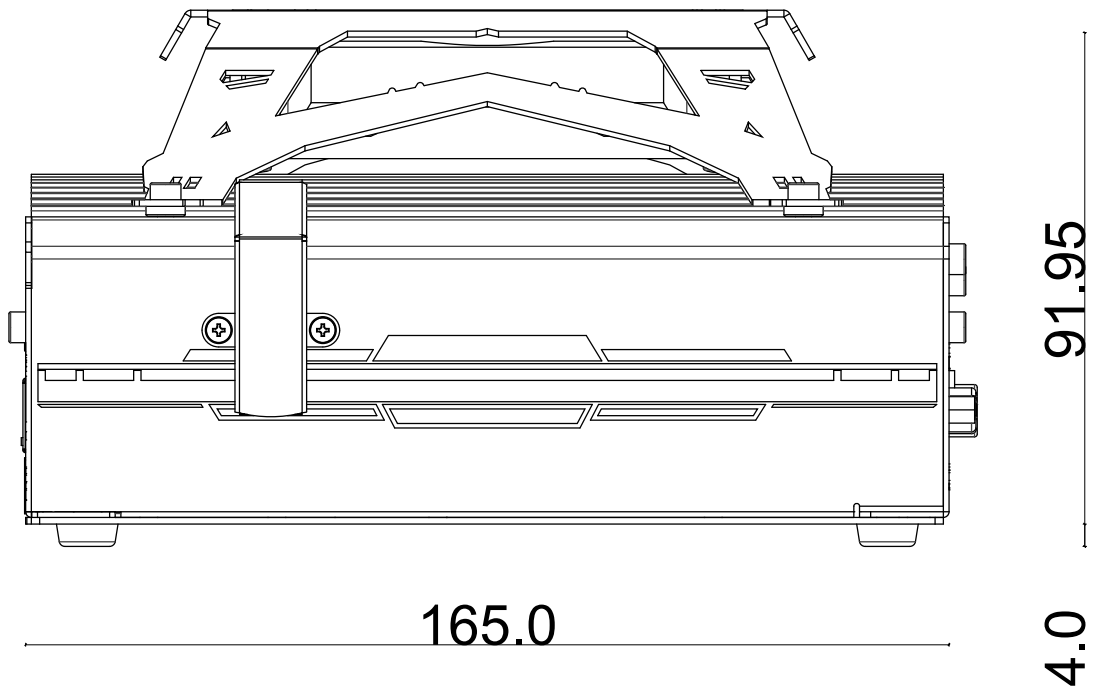

2 System Overview

Upon receiving and unpacking your Nuvo-9531, please check immediately if the package contains all the items listed in the following table. If any item(s) are missing or damaged, please contact your local dealer or Neousys Technology.

2.1 Nuvo-9531 Series Packing List

System Pack	Nuvo-9531	Qty
1	Nuvo-9531 (If you ordered CPU/ RAM/ HDD, please verify these items)	1
2	Accessory box, which contains <ul style="list-style-type: none"> ● CPU bracket ● Wall mount bracket ● mPCIe/ M.2 E key thermal pad ● 3-pin power terminal block ● Screw pack 	1 2 3 1 4

2.1 Nuvo-9531-FT Series Packing List

System Pack	Nuvo-9531-FT	Qty
1	Nuvo-9531-FT (If you ordered CPU/ RAM/ HDD, please verify these items)	1
2	Accessory box, which contains <ul style="list-style-type: none"> ● CPU bracket ● mPCIe/ M.2 E key thermal pad ● 3-pin power terminal block ● Screw pack 	1 3 1 4

2.2 Front Panel I/O



NOTE

Both Nuvo-9531 and Nuvo-9531-FT share the same external connections, therefore Nuvo-9531 illustration will be shown here for demonstration purposes.

The Nuvo-9531 I/O panel features four 2.5G Ethernet ports, four USB3.2 Gen1 ports, one DisplayPort and a 2.5" hot-swappable tray.

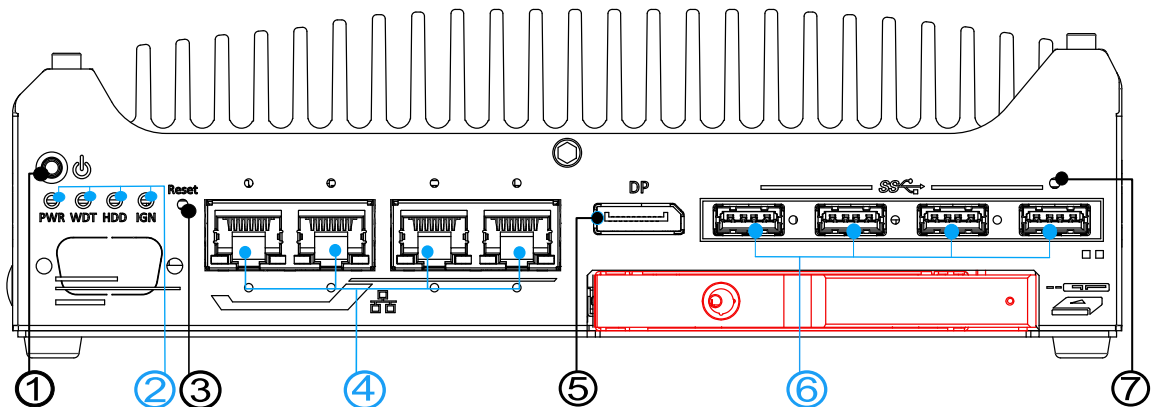

No.	Item	Description
1	Power Button	Use this button to turn on or shutdown the system.
2	System status LEDs	Four system LEDs, power (PWR), watchdog timer (WDT), hard disk drive (HDD) and ignition (IGN).
3	Reset button	Use this button to manually reset the system.
4	2.5G Ethernet Port (optional PoE+)	The 2.5G Ethernet ports support 10/ 100/ 1000/ 2500 Mbps network connections with optional PoE+.
5	DisplayPort	Support display resolutions up to 4096 x 2304. Compatible with HDMI/ DVI via respective adapter cable (resolution may vary).
6	USB3.2 Gen1 Ports	USB 3.2 Gen1 port supports up to 5 Gbit/s data transfer bandwidth.
7	CMOS Reset Button	Use this button to manually reset the CMOS.
	Area in red	2.5" HDD/ SSD hot swappable tray

2.3.1 Power Button

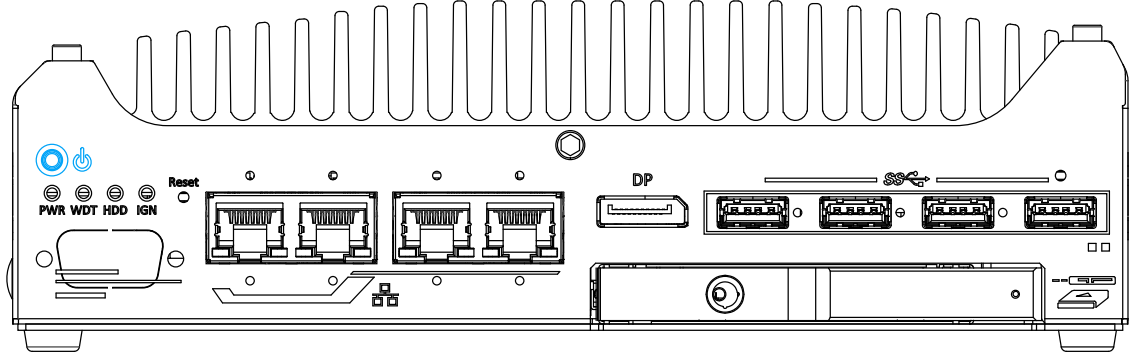

The power button is a non-latched switch for ATX mode on/off operation. Press to turn on the system, PWR LED should light up and to turn off, you can either issue a shutdown command in the OS, or just press the power button. In case of system halts, you can press and hold the power button for 5 seconds to force-shutdown the system. Please note that there is a 5 seconds interval between two on/off operations (i.e. once turning off the system, you will need to wait for 5 seconds to initiate another power-on operation).

2.3.2 System Status LED

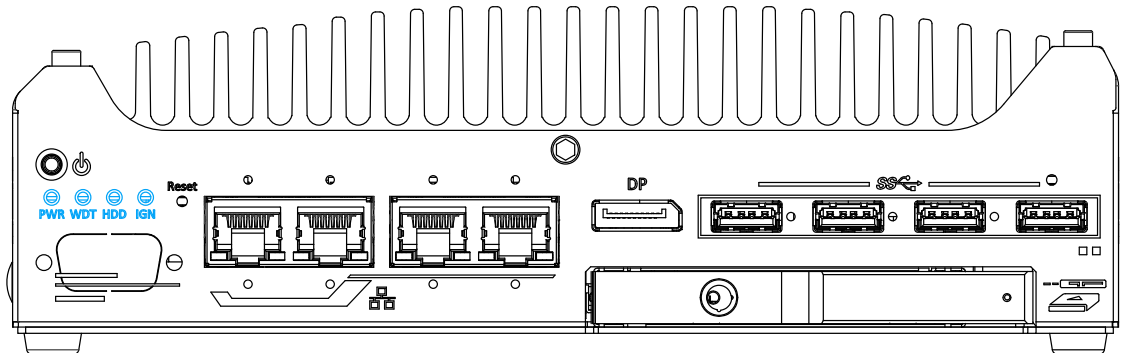

There are four LED indicators on the I/O panel: PWR, WDT, HDD and IGN. The descriptions of these LEDs are listed in the following table.

Indicator	Color	Description
PWR	Green	Power indicator, lighted-up when system is on.
WDT	Yellow	Watchdog timer LED, flashing when watchdog timer is started.
HDD	Red	Hard drive indicator, flashing when hard drive is active.
IGN	Green	An optional feature. Ignition signal indicator, lid when IGN is high (12V/ 24V).

2.3.3 Reset Button

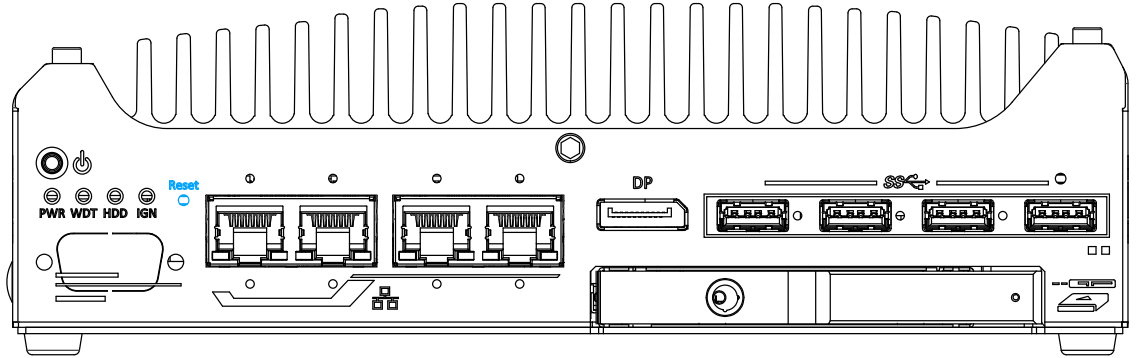

The reset button can be used to manually reset the system in case of abnormal condition. To avoid unexpected operation, the reset button is hidden behind the front panel. You need to use a pin-like object to push the reset button.

2.3.4 2.5G Ethernet Port (Optional PoE+)

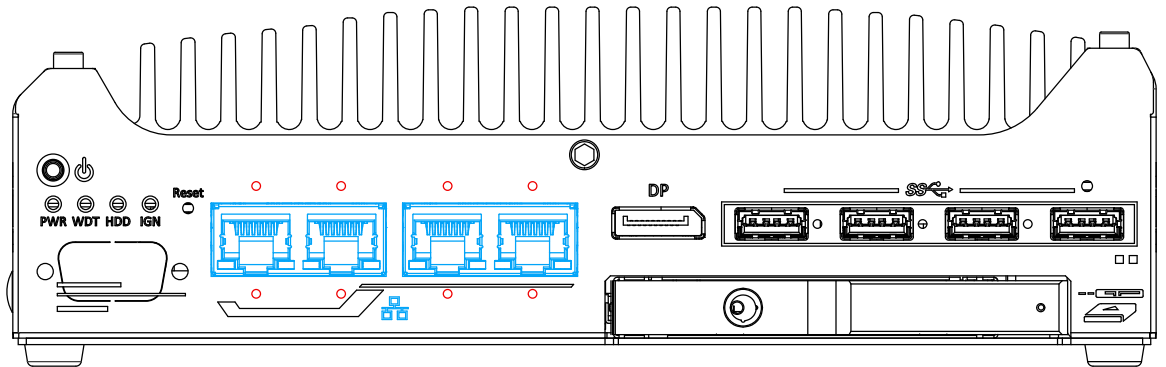

The system offers four 2.5Gb Ethernet ports using Intel® I226 controller, and each port each come with screw-lock mechanism (indicated in **red**). When plugged in and connected via the Ethernet cable, the LEDs on the RJ45 connector indicate connection status and speed. Optional Power over Ethernet (PoE) is available to supply electrical power and data over a standard CAT-5/CAT-6 Ethernet cable. Acting as a PoE PSE (Power Sourcing Equipment), compliant with IEEE 802.3at, each PoE port delivers up to 25W to a Powered Device (PD). PoE can automatically detect and determine if the connected device requires power or not, so it is compatible with standard Ethernet devices as well.

Active/Link LED

LED Color	Status	Description
Orange	Off	Ethernet port is disconnected
	On	Ethernet port is connected and no data transmission
	Flashing	Ethernet port is connected and data is transmitting/receiving

Speed LED

LED Color	Status	Description
Green or Orange	Off	10 Mbps
	Green	100 Mbps
	Orange	1000/ 2500 Mbps

2.3.5 DisplayPort

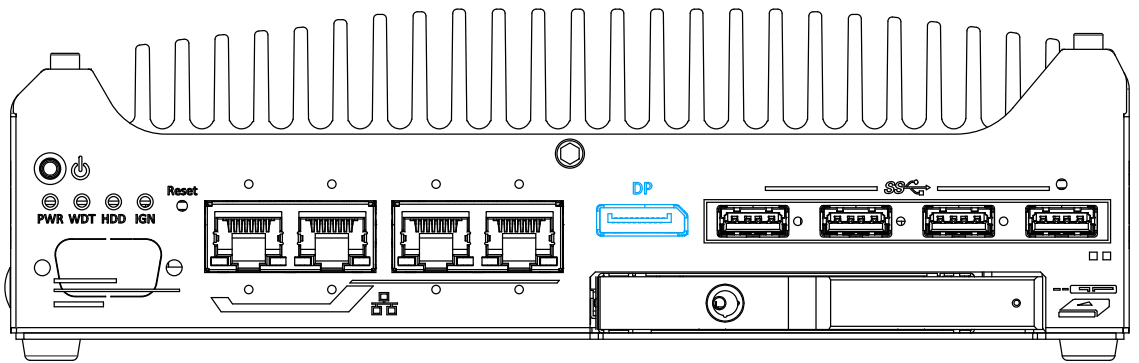

The system has a DisplayPort (DP) output which is a digital display interfaces that mainly connect video source and carry audio to a display device. When connecting a DP, it can deliver up to 4K UHD (4096 x 2304) in resolution. The system is designed to support passive DP adapter/ cable. You can connect to other display devices using DP-to-HDMI cable or DP-to-DVI cable.



DP-to-HDMI



DP-to-DVI

With the VGA output on the rear panel, the system supports dual independent display outputs. To support dual display outputs and achieve best VGA/ DisplayPort output resolution in Windows, you need to install corresponding graphics drivers. Please refer to section [Driver Installation](#) for details.

2.3.6 USB3.2 Gen1 Ports

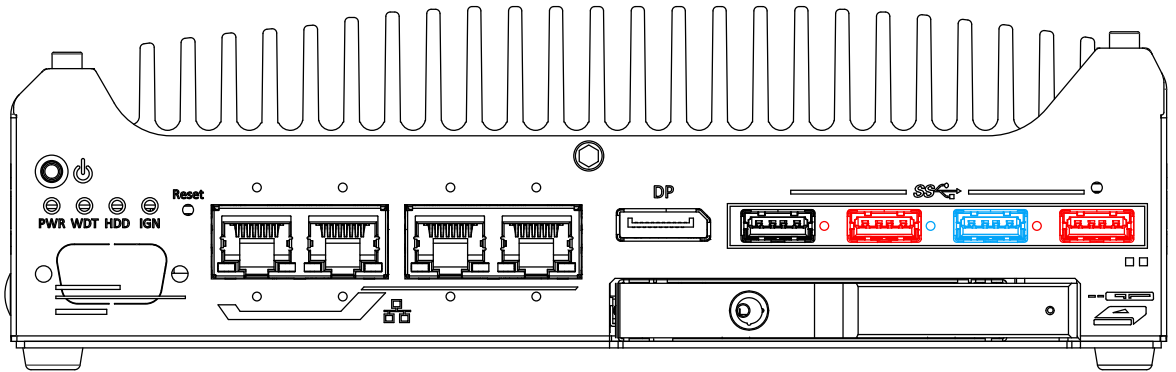

The system offers four USB 3.2 Gen1 (SuperSpeed USB) ports on its front panel with screw-lock mechanism. They are backward compatible with USB 2.0, USB 1.1 and USB 1.0 devices. UEFI USB is also supported so you can use USB keyboard/ mouse in UEFI shell environment. USB 3.2 Gen1 driver is supported natively in Windows 10. The screw-lock mechanism is available on the three ports indicated in blue and red, and due to the width of the screw-lock connector, only the USB ports indicated in red can be connected simultaneously when using the screw-lock mechanism.



NOTE

Depending on the design of your screw-lock USB connector, the CMOS reset button may be obstructed by the connected USB port below.

2.3.7 CMOS Reset Button

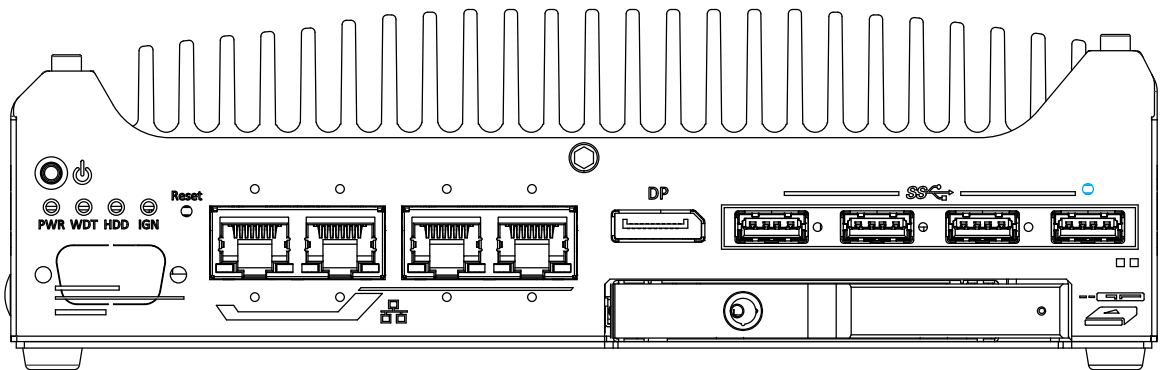

The CMOS Reset button is used to manually reset the motherboard BIOS in case of system halt or malfunction. To avoid unexpected operation, it is purposely placed behind the panel. To reset, please use the tip of a pen, press and hold for at least 5 seconds to reset the BIOS.

2.3.8 2.5" HDD/ SSD Hot-swappable Tray

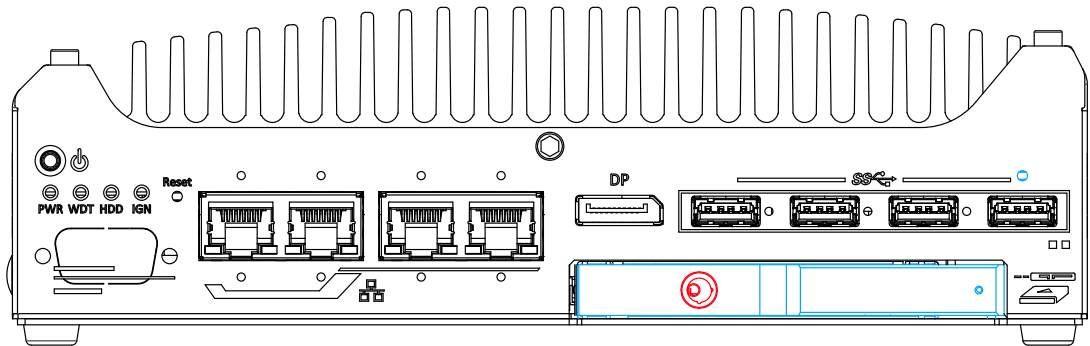

The system features an external hot-swappable 2.5" hot-swappable tray that supports a 7mm 2.5" HDD/ SSD. Designed for easy access, the HDD tray is secured by a lock (indicated in **red**).

2.2 Rear Panel I/O

On the rear panel of the system, you will find a 3-pin terminal block for DC input, two USB2.0 ports for legacy USB devices, two configurable COM ports, a 4-pole female 3.5mm headphone (speaker)/ microphone jack and a digital input/ output DB15 connector.

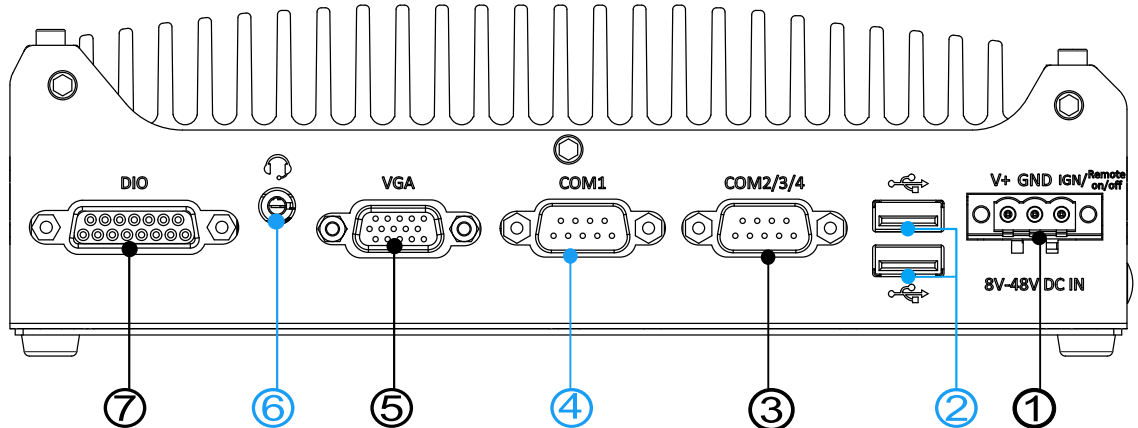

No.	Item	Description
1	3-pin Terminal Block DC Input with Remote On/Off (Optional Ignition Power Control)	Compatible with DC power input from 8~48V, the terminal block is also used for ignition signal input. The remote on/off function allows for an external switch extension when the system is placed within a cabinet.
2	USB2.0 Ports	The USB 2.0 ports are backward with USB 1.1 / 1.0.
3	COM2/3/4 Port	Can be configured as: COM2: single RS-422/ 485 port COM2/ COM3/ COM4: three 3-wire RS-232 ports
4	COM1 Port	Software programmable RS-232/ 422/ 485 port.
5	VGA Port	VGA output supports resolution up to 1920x1200@60Hz
6	4-Pole 3.5mm Microphone-in/ Speaker-out Jack	The 4-pole 3.5mm jack accepts microphone voice input and headphone speaker sound output.
7	DIO Port	The port provides four DI and four DO via DB15 female connector

2.4.1 3-pin DC Input with Remote On/ Off (Optional Ignition Power Control)

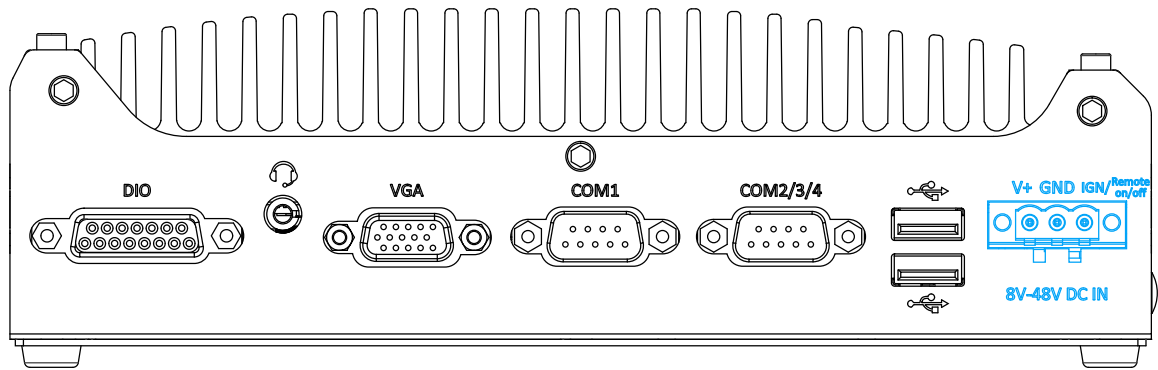

The system accepts a wide range of DC power input from 8 to 48V via a 3-pin pluggable terminal block, which is fit for field usage where DC power is usually provided. The screw clamping mechanism on the terminal block offers connection reliability when wiring DC power. The Remote On/ Off connection allows for external switch extension. It is useful when the system is placed in a cabinet or a not easily accessed location. By connecting the DC in and remote on/ off pins, it activates the “always on” setting that automatically detects the system status to stay powered on.

In addition to DC power input and Remote On/ Off, this terminal block can also accept optional ignition signal input (IGN) for in-vehicle applications.

2.4.2 USB2.0 Ports

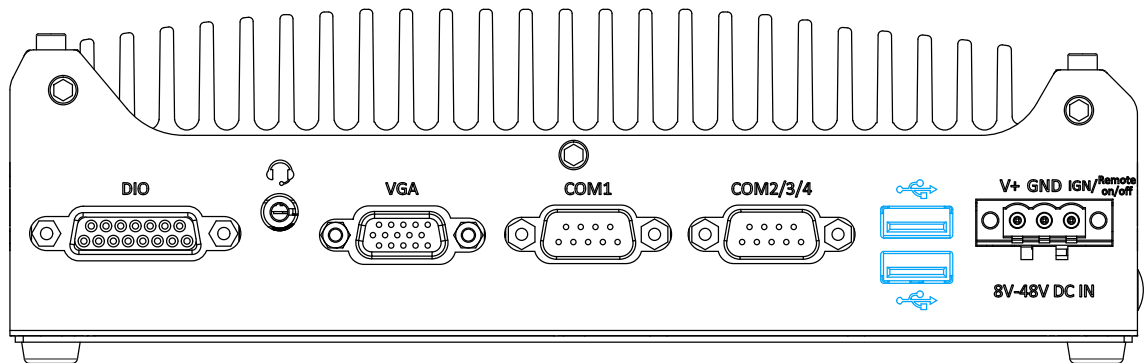

The USB2.0 ports are implemented via native xHCI (eXtensible Host Controller Interface) in the Intel 600 chipset and are backward compatible with USB 1.1 and USB 1.0 devices. UEFI USB support is also provided so you can use USB keyboard/ mouse in UEFI shell environment.

xHCI driver is supported natively in Windows 10, therefore you do not need to install xHCI driver to utilize USB functions.

2.4.3 COM2/3/4 Port

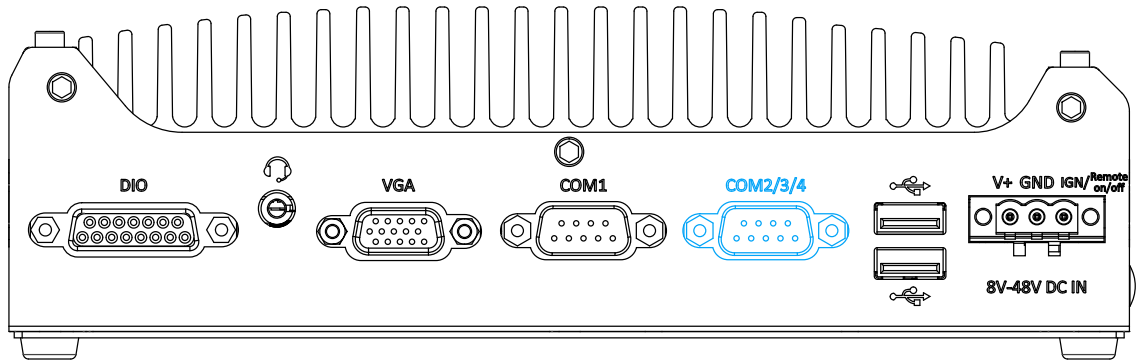

Implemented using industrial-grade ITE8786 Super IO chip (-40 to 85°C) and provide up to 921600 bps baud rate, the D-Sub male connector (COM2/ 3/ 4) can be configured in the BIOS as single RS-422/ 485 port (COM2) or three 3-wire RS-232 ports (COM2/COM3/COM4). Please refer to [COM2/ 3/ 4 Port Configuration](#) for configuring operation mode. An optional 1-to-3 Y-cable is available to connect three RS-232 devices.

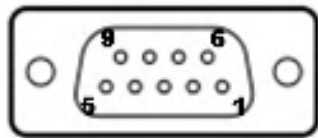

COM2/ 3/ 4 Pin



1-to-3 Y-cable

The following table describes the pin definition of the COM port

	3-port RS-232 COM2/ 3/ 4		
Pin#	COM2	COM3	COM4
1			
2	RX		
3	TX		
4		TX	
5	GND	GND	GND
6		RX	
7			TX
8			RX
9			

	Single port RS-422/ 485 COM2	
Pin#	RS-422	RS-485
1		
2	TxD+	TxD+/ RxD+
3	RxD+	
4	RxD-	
5	GND	GND
6		
7		
8	TxD-	TxD-/ RxD-
9		

2.4.4 COM1 Port

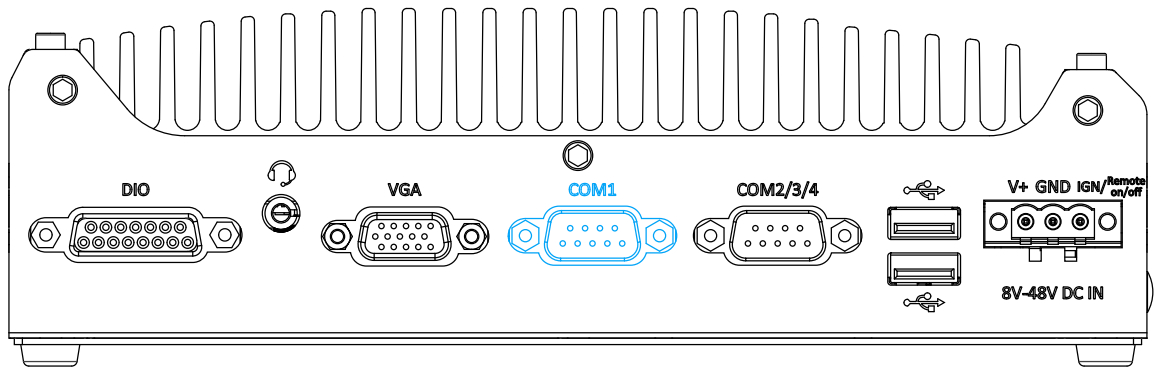

Implemented using industrial-grade ITE8786 Super IO chip (-40 to 85°C) and provide up to 921600 bps baud rate, COM1 is a software-configurable RS-232/422/485 port via 9-pin D-Sub male connector. The operation mode, slew rate and termination of COM1 can be set in BIOS setup utility. The following table describes the pin definition of COM ports.

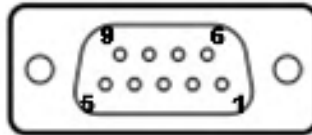

Pin#	COM1		
	RS-232 Mode	RS-422 Mode	RS-485 Mode (Two-wire 485)
1	DCD		
2	RX	422 TXD+	485 TXD+/RXD+
3	TX	422 RXD+	
4	DTR	422 RXD-	
5	GND	GND	GND
6	DSR		
7	RTS		
8	CTS	422 TXD-	485 TXD-/RXD-
9	RI		

2.4.5 VGA Port

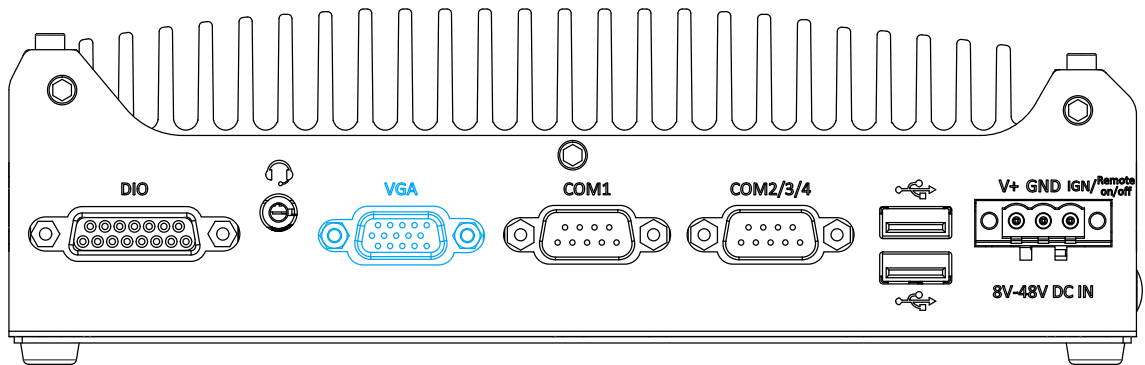

VGA connector is the most common video display connection. The VGA output supports up to 1920x1200@60Hz resolution. With the DisplayPort on the front panel, the system supports dual independent display outputs. To support dual display outputs and achieve best VGA/ DisplayPort output resolution in Windows, you need to install corresponding graphics drivers.



NOTE

Please make sure your VGA cable includes SDA and SCL (DDC clock and data) signals for correct communication with monitor to get resolution/timing information. A cable without SDA/ SCL can cause blank screen on your VGA monitor due to incorrect resolution/timing output.

2.4.6 4-Pole 3.5mm Microphone-in/ Speaker-out Jack

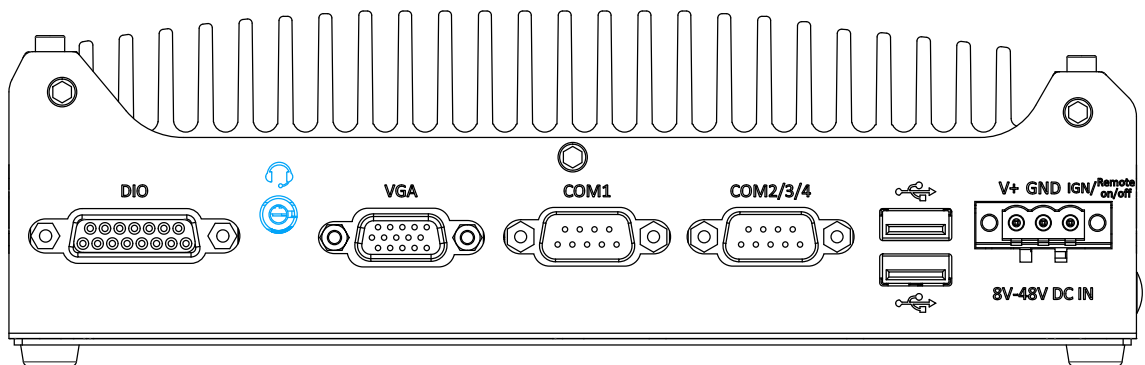

There is a female 4-pole  audio jack for headphone (speaker) output and microphone input. To utilize the audio function in Windows, you need to install corresponding drivers. Please refer to the section, [Driver Installation](#).

2.4.7 DIO Port Pin Definition & Wiring

The digital input (DI) and digital output (DO) function provides four digital input and four digital output on the rear panel of the system via DB15 female connector.

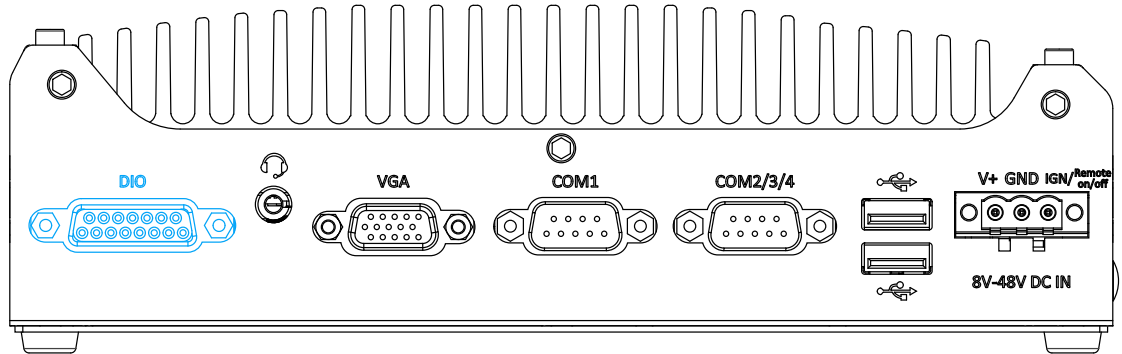

Isolated Digital Input

No. of Channel	4-CH Isolated Digital Input Channels
Logic Level	Logic High: 5 to 24V Logic Low: 0 to 1.5V
Isolated Voltage	2500 Vrms
Input Resistance	1kΩ
Operation Mode	Polling

Isolated Digital Output

No. of Channel	4-CH Isolated Digital Output Channels
Sink Current (per channel)	500 mA
Isolated Voltage	1500 Vrms
Operation Mode	Polling

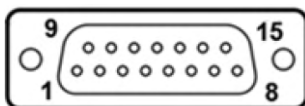

Pin Definition

Pin#	Pin Definition	Pin#	Pin Definition
1	DI_0	9	DI_GND
2	DI_1	10	DI_2
3	DI_GND	11	DI_3
4	DO_COM	12	DO_COM
5	DO_0	13	DO_2
6	DO_1	14	DO_3
7	DO_COM	15	-
8	VDD		

Wiring for DIO

The digital input function is implemented using a photo-coupler with an internally series-connected 1kΩ resistor. You need to provide a voltage to specify the logic high/low state. The input voltage for logic high is 5~24V, and the input voltage for logic low is 0~1.5V.

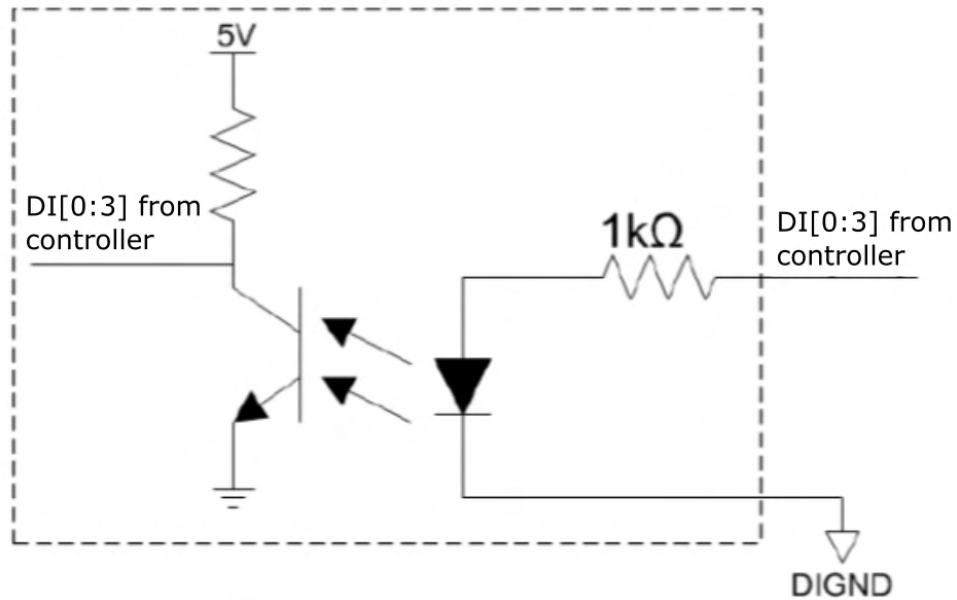

The digital output function is implemented using photomos component. When you turn on the system, all DO channels are in off state (circuit disconnected from DO_COM). The digital output function on the system supports sink current connection and source current connection. However, DO0~ DO3 should be connected with the same connection type. Either sink type or source type can be used for DO0~DO3 at the same time.

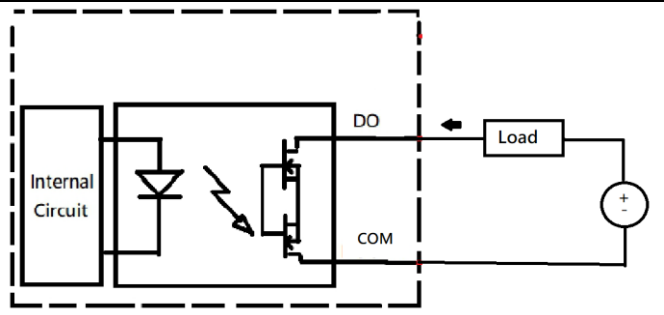
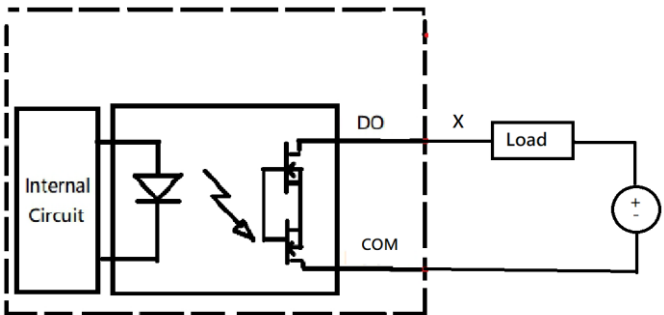
State	Connection Type	Sink Type
On state Do output as 0		
Off state Do output as 1		

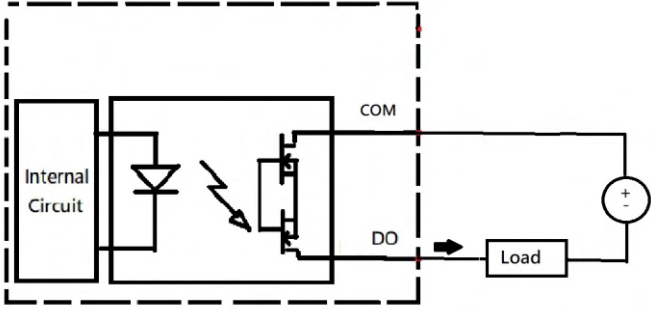
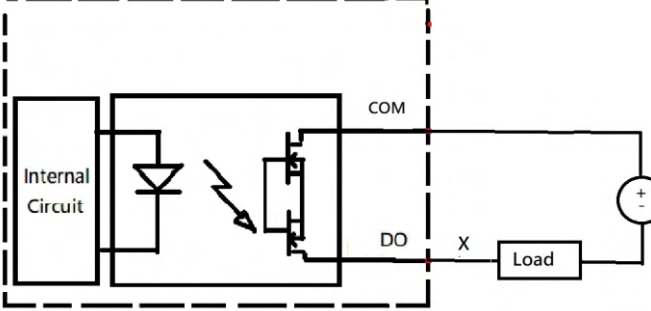
State / Connection Type	Source Type
<p>On state Do output as 0</p>	
<p>Off state Do output as 1</p>	

2.5 Internal I/O Functions

In addition to I/O connectors on the front panel, the system also provides internal on-board expansion slots. In this section, we'll illustrate these internal I/O functions.

2.5.1 M.2 2280 Slot for SSD (PCIe Gen4 x4)

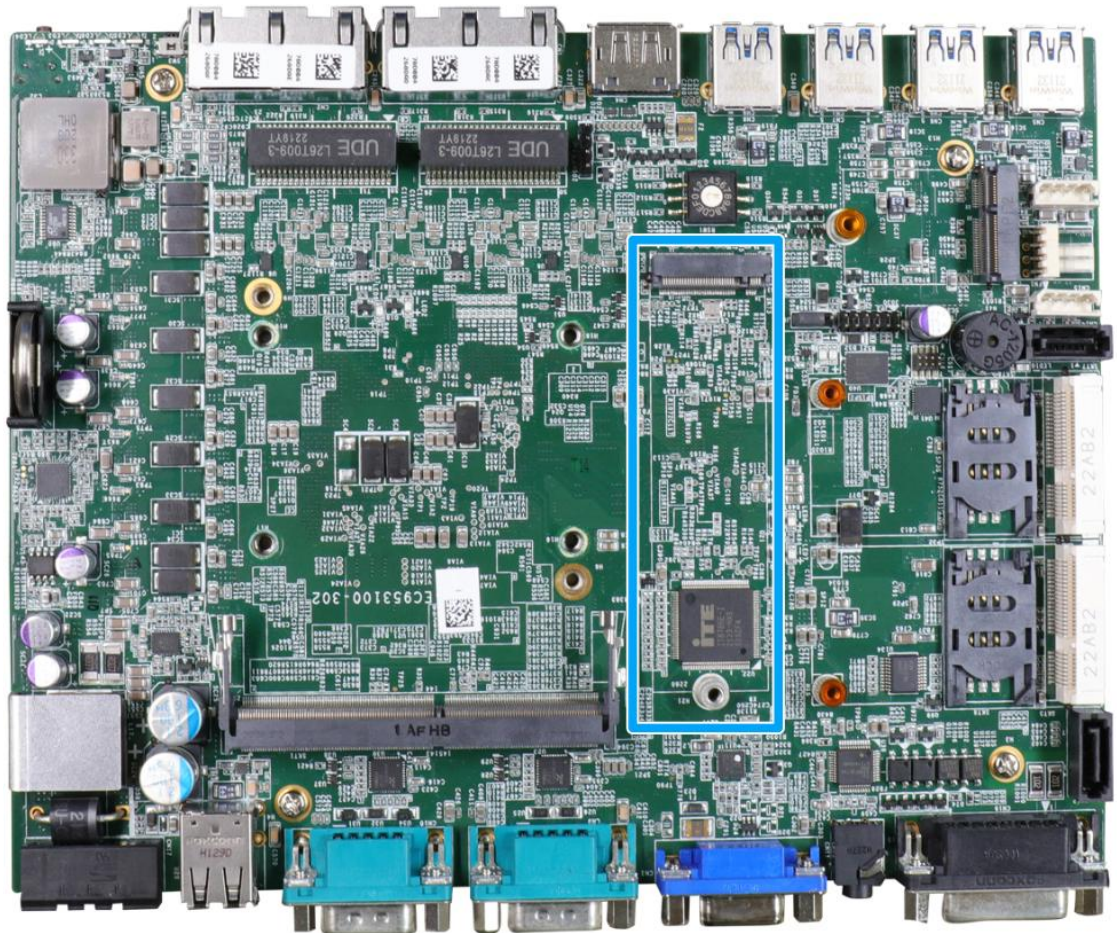

The system has a Gen4 x4 PCIe M.2 2280 slot for you to install an NVMe SSD. The M.2 NVMe SSD offers significantly better system performances when compared to a 2.5" SSD.

M.2 2280M Key Pin Definition

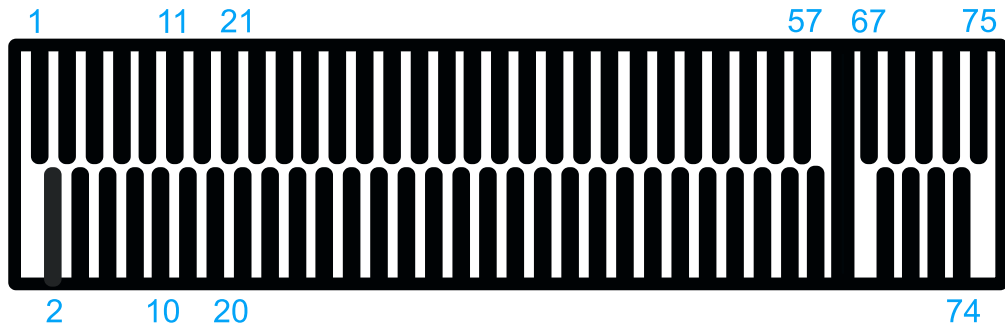

Pin #	Signal	Pin #	Signal
1	GND	2	+3V3
3	GND	4	+3V3
5	PERN3	6	-
7	PERP3	8	-
9	GND	10	DAS/DSS_N
11	PETN3	12	+3V3
13	PETP3	14	+3V3
15	GND	16	+3V3
17	PERN2	18	+3V3
19	PERP2	20	-
21	GND	22	-
23	PETN2	24	-
25	PETP2	26	-
27	GND	28	-
29	PERN1	30	-
31	PERP1	32	-
33	GND	34	-
35	PETN1	36	-
37	PETP1	38	-
39	GND	40	-
41	PERn0	42	-
43	PERp0	44	-
45	GND	46	-
47	PETn0	48	-
49	PETp0	50	PERST_N
51	GND	52	-
53	REFCLKN	54	-
55	REFCLKP	56	-
57	GND	58	-
Mechanical Key			
67	-	68	SUSCLK
69	PEDET	70	+3V3
71	GND	72	+3V3
73	GND	74	+3V3
75	GND		

2.5.2 Single DRAM SO-DIMM Slot

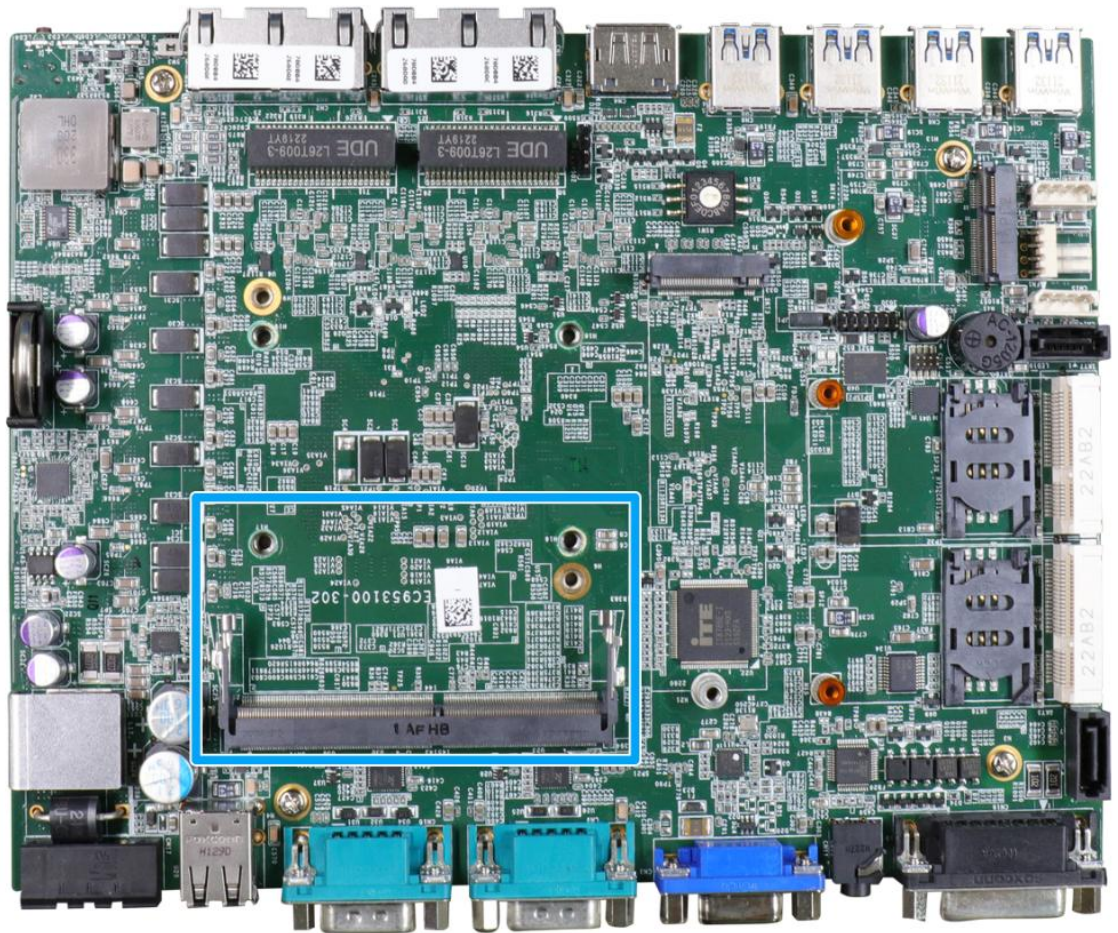

The system motherboard supports one 260-pin SODIMM socket for installing one non-ECC DDR4-3200 memory module up to 32GB capacity.

2.5.3 mini-PCIe Slot

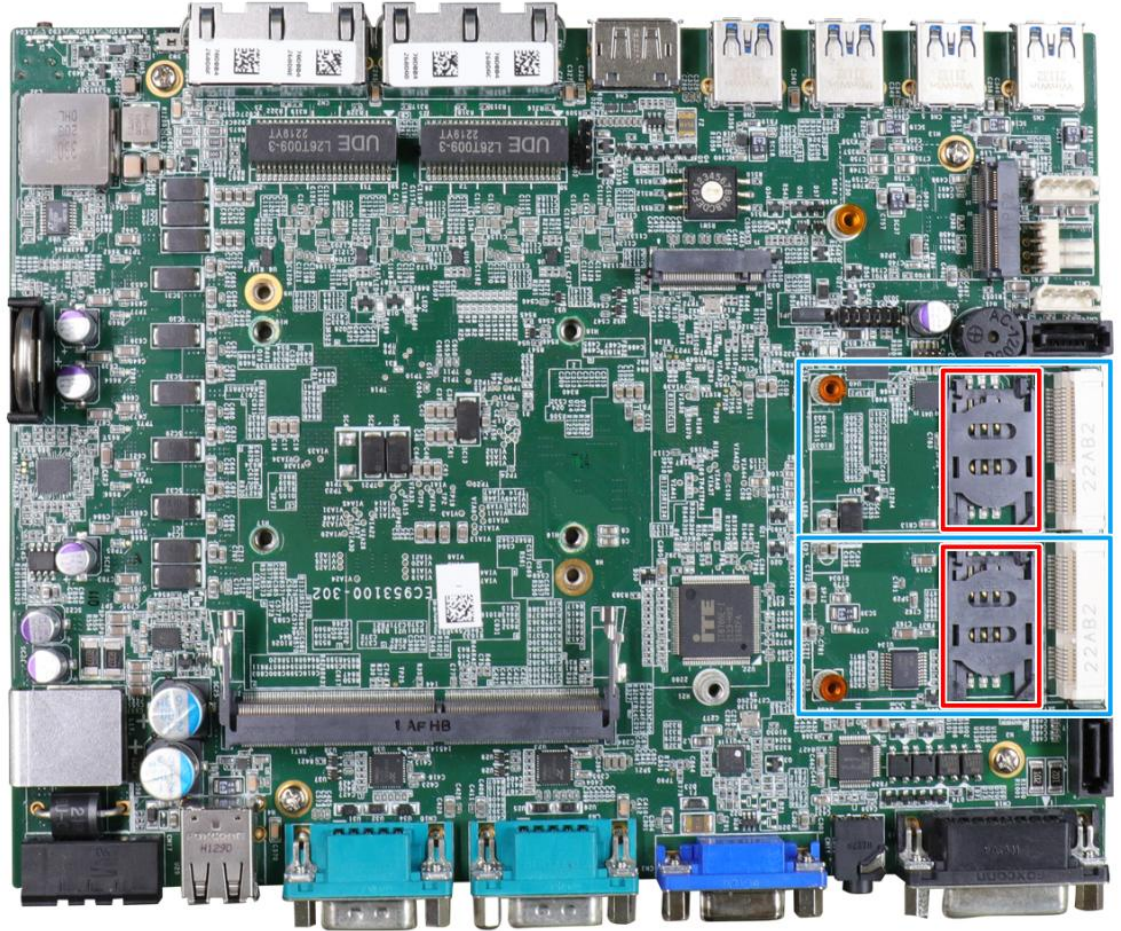

The system has two mini-PCIe sockets and there are plenty of off-the-shelf mini-PCIe modules with versatile capabilities. By installing a mini-PCIe module, your system can have expanded features such as WIFI, GPS, CAN bus, etc.

For SMA antenna installation, there are dedicated openings on the side of the chassis.

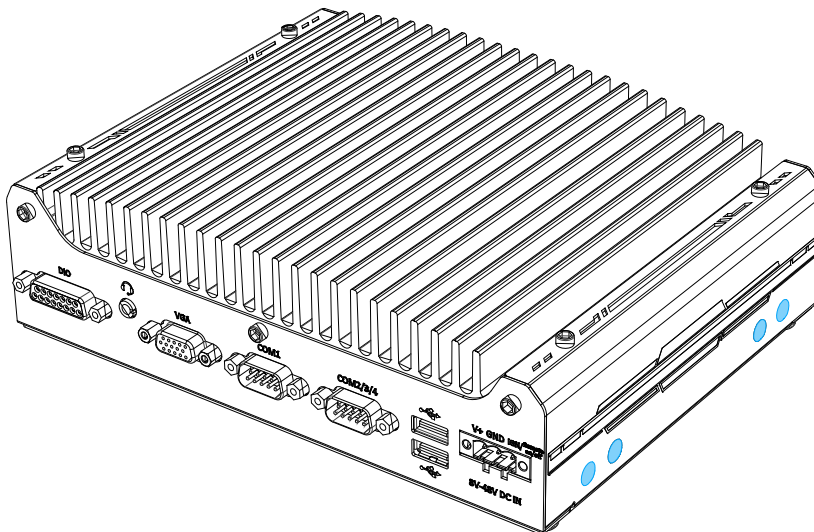

mini-PCle slot definition

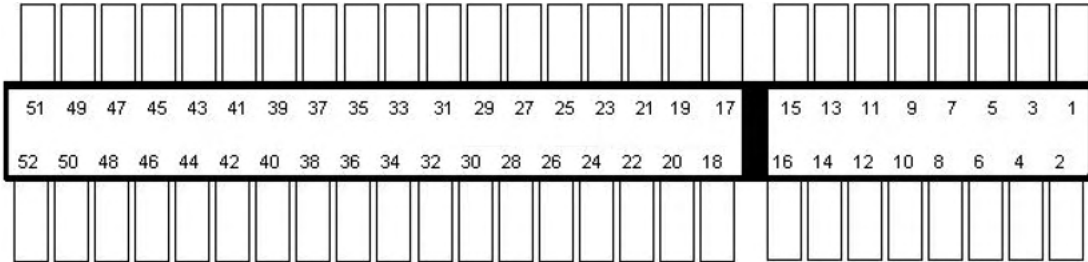

Pin #	Signal	Pin #	Signal
1	WAKE#	2	+3.3Vaux
3	COEX1	4	GND
5	COEX2	6	+1.5V
7	CLKREQ#	8	UIM_PWR
9	GND	10	UIM_DATA
11	REFCLK-	12	UIM_CLK
13	REFCLK+	14	UIM_RESET
15	GND	16	UIM_VPP
Mechanical Key			
17	Reserved* (UIM_C8)	18	GND
19	Reserved* (UIM_C4)	20	W_DISABLE#
21	GND	22	PERST#
23	PERn0	24	+3.3Vaux
25	PERp0	26	GND
27	GND	28	+1.5V
29	GND	30	SMB_CLK
31	PETn0	32	SMB_DATA
33	PETp0	34	GND
35	GND	36	USB_D-
37	GND	38	USB_D+
39	+3.3Vaux	40	GND
41	+3.3Vaux	42	Reserved
43	GND	44	Reserved
45	Reserved	46	Reserved
47	Reserved	48	+1.5V
49	Reserved	50	GND
51	Reserved	52	+3.3Vaux

2.5.4 Ignition Rotary Switch

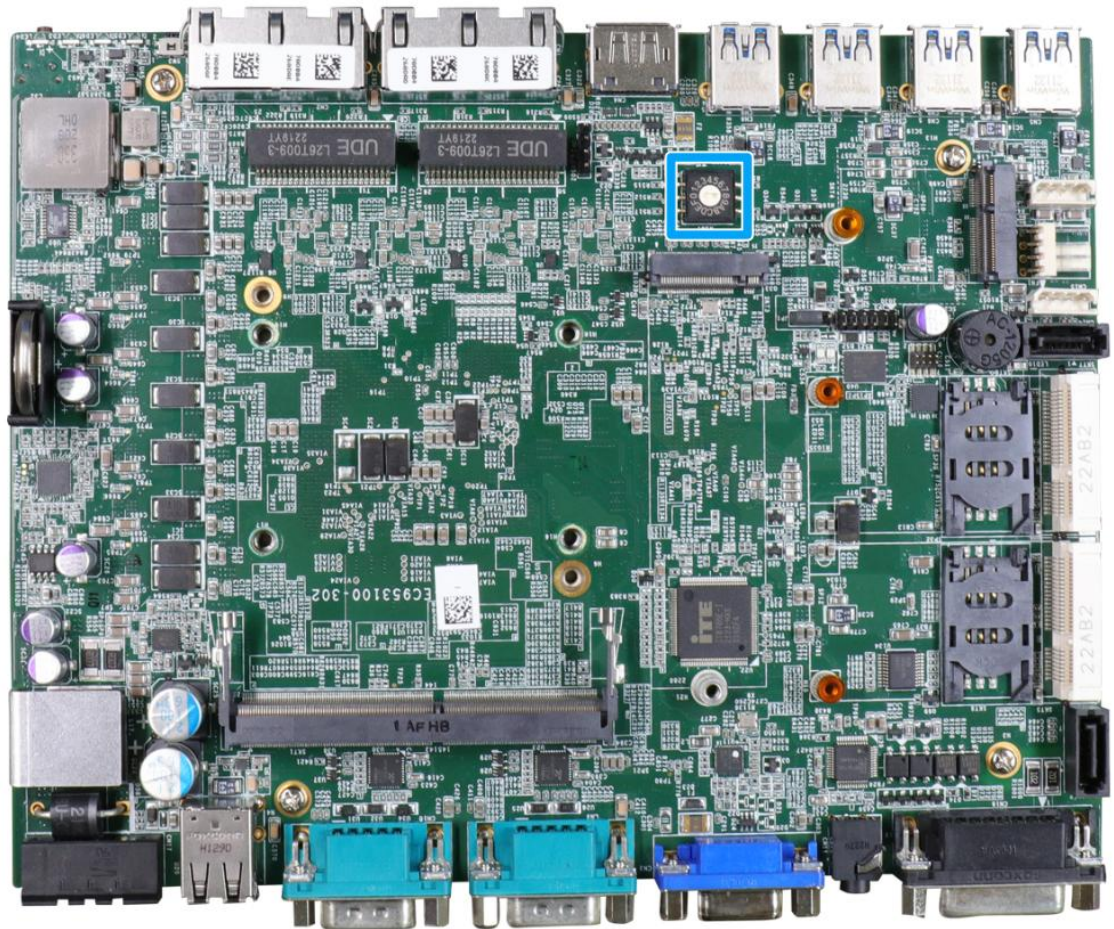

The ignition power control switch features multiple modes for pre and post ignition settings. Please refer to the section [Ignition Power Control](#) for details.

2.5.5 SATA Port

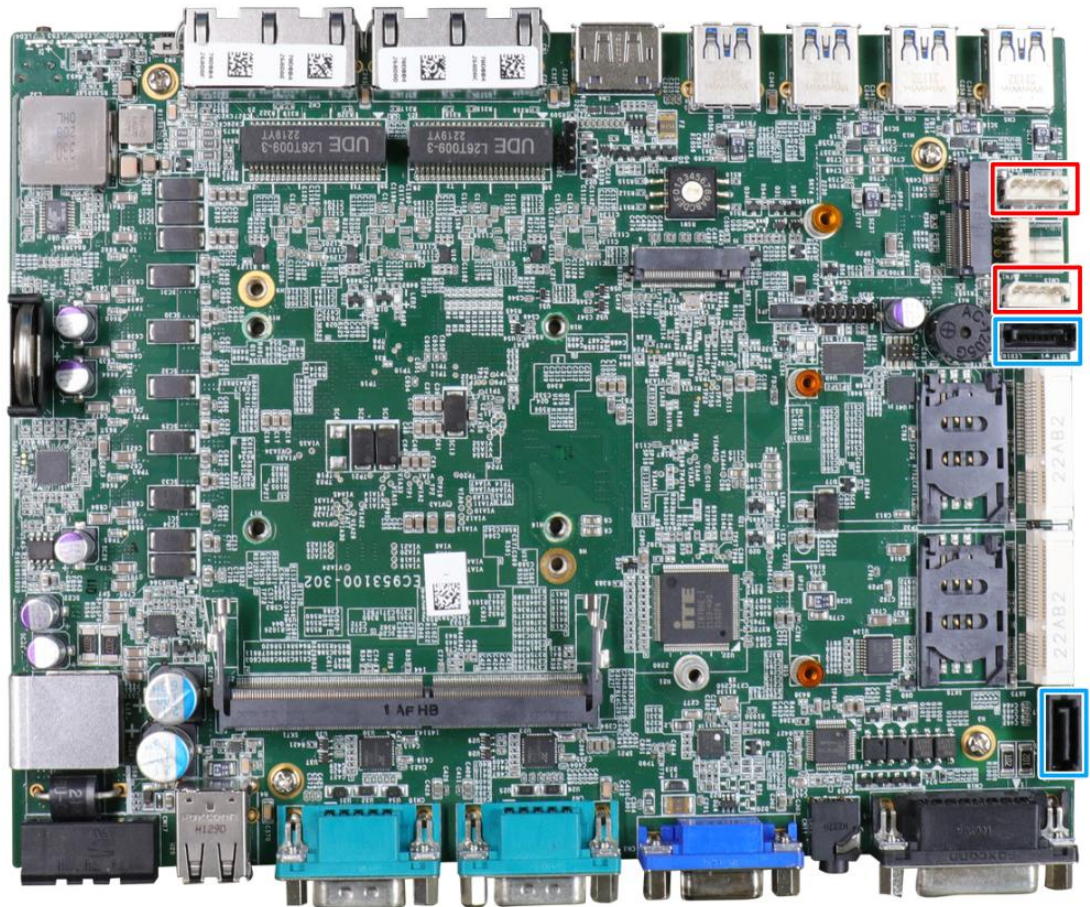

The system provides two SATA ports which support Gen3, 6 Gb/s SATA signals. The SATA ports are composed of a 7-pin SATA connector (indicated in **blue**) and a 4-pin power connector (indicated in **red**).

2.5.6 M.2 2230 E Key Slot

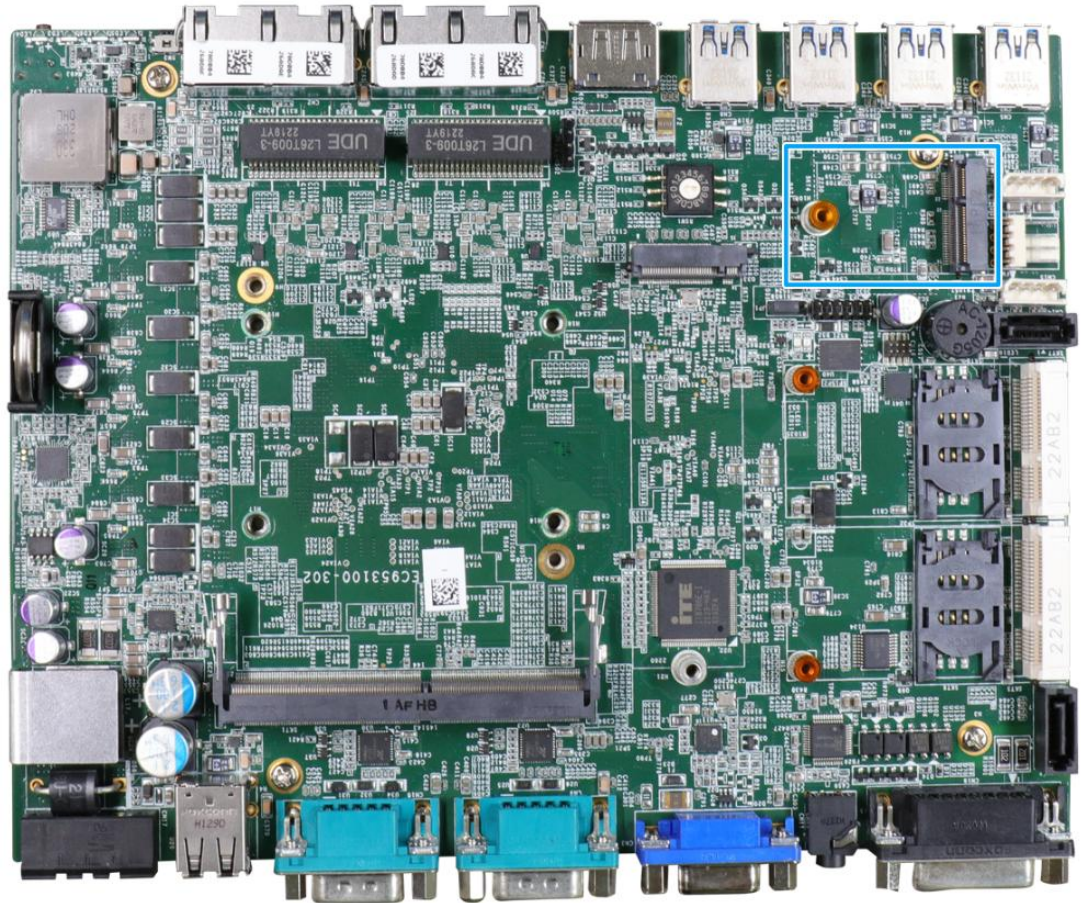

The system has an M.2 2230 E key socket that offers PCIe Gen3 x1 and USB2.0 signal for WiFi 6/ 5 or Google TPU module installation.

For SMA antenna installation, there are dedicated openings on both sides of the chassis.

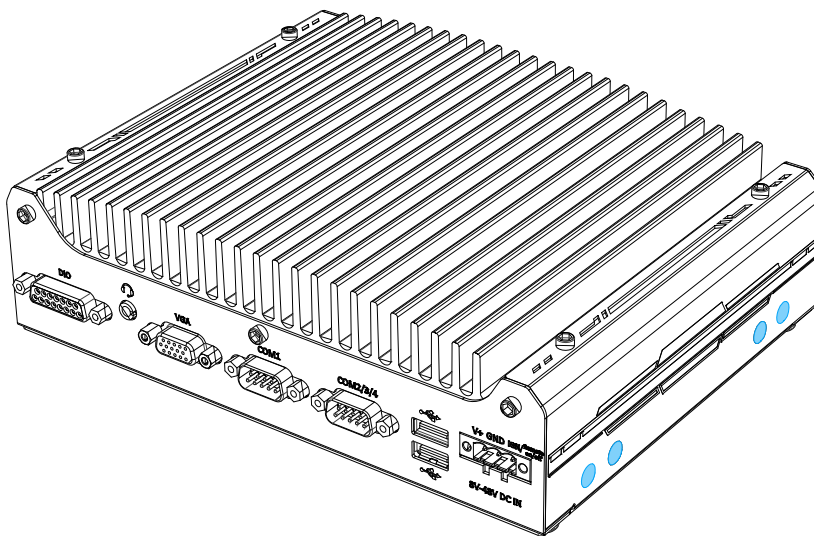

M.2 2230 E Key Pin Definition

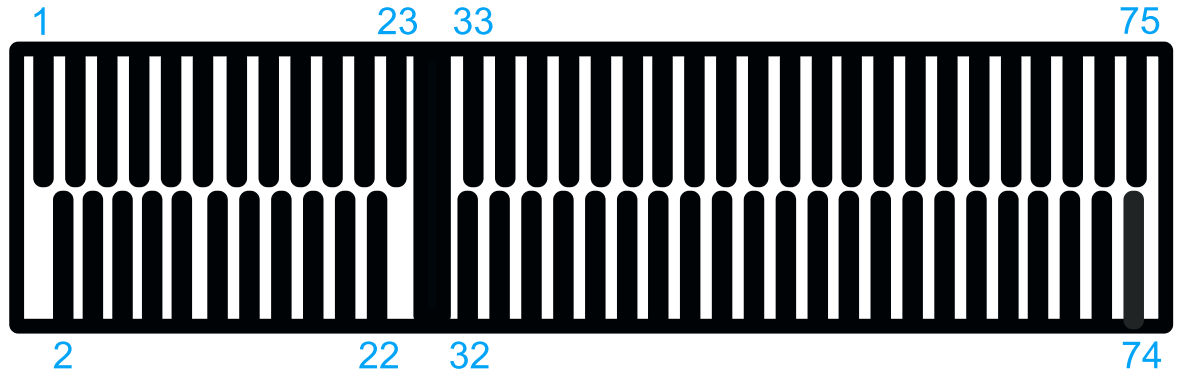

Pin #	Signal	Pin #	Signal
1	GND	2	+3V3
3	USB_D+	4	+3V3
5	USB_D-	6	
7	GND	8	
9		10	-
11		12	
13		14	
15		16	
17		18	GND
19		20	
21	-	22	-
23	-		
Mechanical Key			
33	GND	32	
35	PETP0	34	
37	PETN0	36	
39	GND	38	
41	PER P0	40	
43	PER N0	42	
45	GND	44	
47	REFCLK_P0	46	
49	REFCLK_N0	48	
51	GND	50	
53	CLKREQ#	52	PERST#
55		54	
57	GND	56	W_DISABLE#
59		58	
61		60	
63	GND	62	
65		64	
67		66	
69	GND	68	
71		70	
73		72	+3V3
75	GND	74	+3V3

2.5.7 On/ Off Ctrl & Status Output

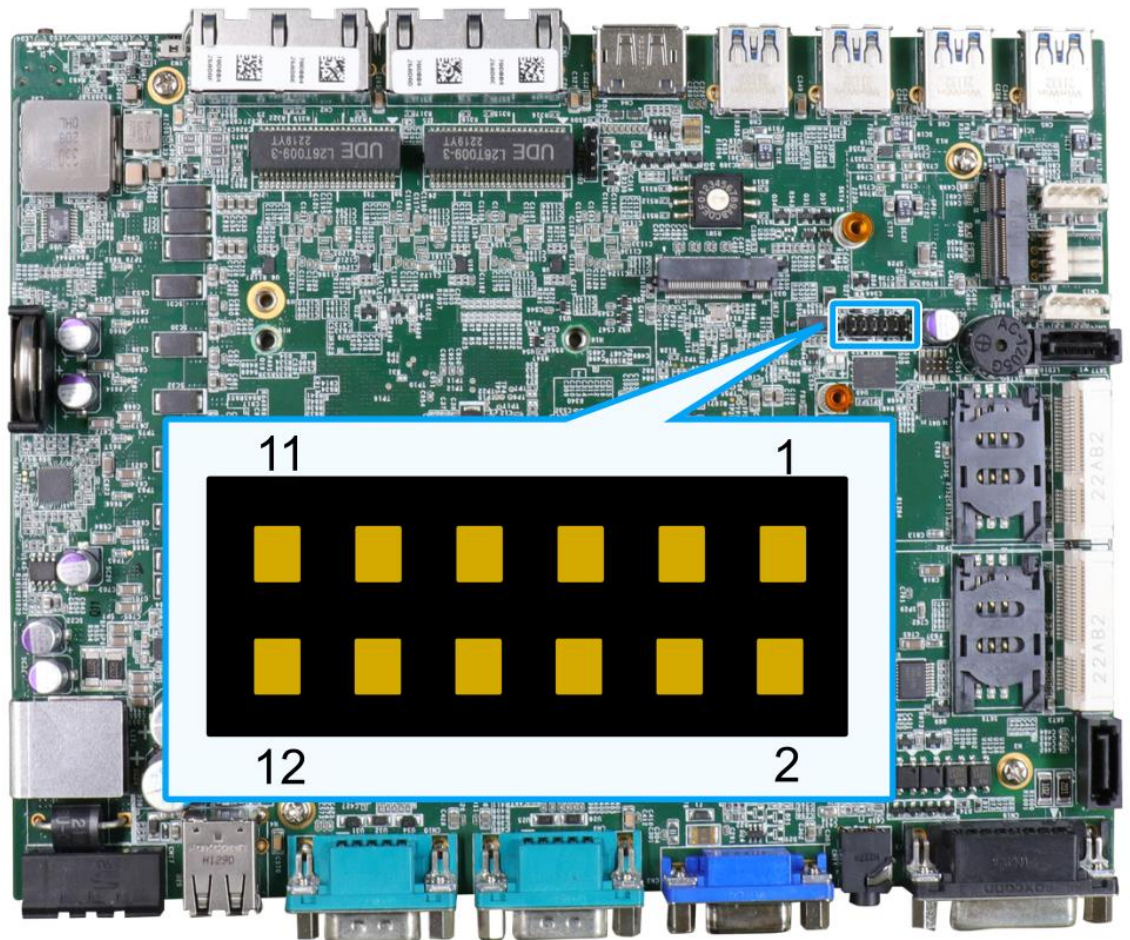

Pin#	Definition	Description
1	WDT_LED-	[Output] Watchdog timer indicator, flashing when Watchdog timer is active
2	WDT_LED+	
3	Standby Power-	[Output] Standby power indicator, on if DC power is applied and system is in S5 (standby) mode.
4	Standby Power+	
5	HDD-	[Output] Hard drive indicator, flashing when SATA hard drive is active.
6	HDD+	
7	Power-	[Output] System power indicator, on if system is turned on, off if system is turned off.
8	Power+	
9	Ctrl-	[Input] Remote on/off control, connects to an external switch to turn on/off the system (polarity is negligible).
10	Ctrl+	
11	IGN_LED-	[Output] Ignition control indicator, on if ignition control is on, off if ignition control is off.
12	IGN_LED+	

3 System Installation

Before disassembling the system enclosure and installing components and modules, please make sure you have done the following:

- It is recommended that only qualified service personnel should install and service this product to avoid injury or damage to the system.
- Please observe all ESD procedures at all times to avoid damaging the equipment.
- Before disassembling your system, please make sure the system has powered off, all cables and antennae (power, video, data, etc.) are disconnected.
- Place the system on a flat and sturdy surface (remove from mounts or out of server cabinets) before proceeding with the installation/ replacement procedure.

3.1 Disassembling Nuvo-9531

To access Nuvo-9531 internal components, the enclosure needs to be disassembled. To disassemble the system enclosure, please refer to the procedures below:

1. Turn the system upside-down on a steady surface. Remove the screws indicated and separate the bottom panel from the system's enclosure. Disconnect the SATA and 4-pin power cable from the motherboard.

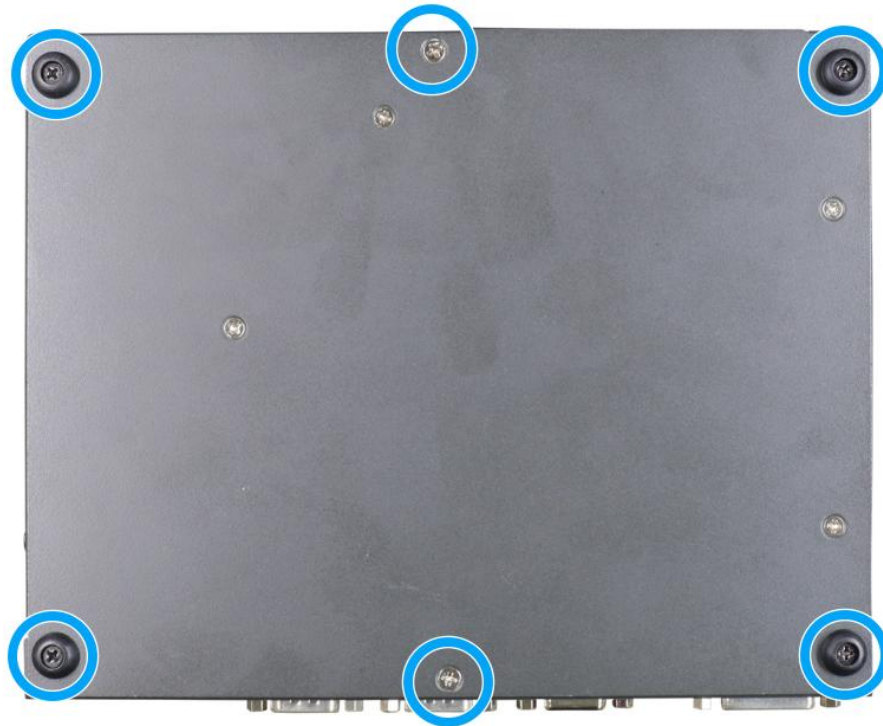

2. Remove the screw indicated on the rear I/O panel.



3. Remove the screws indicated on the front I/O panel.

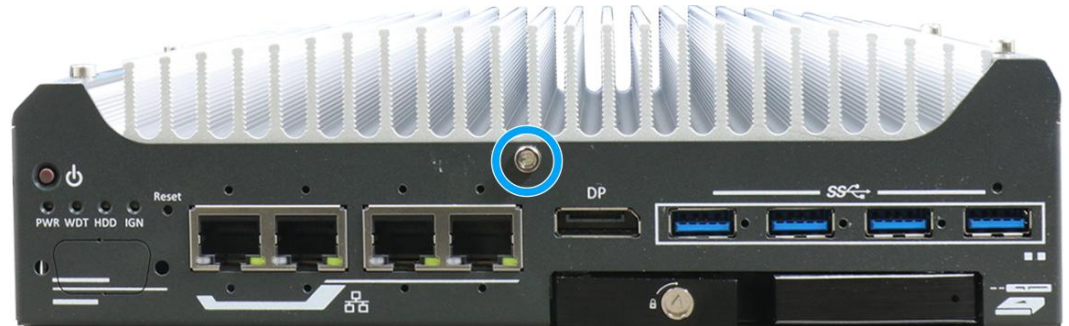

4. Remove the screws from the top of the heatsink and separate the motherboard/ heatsink from the enclosure.

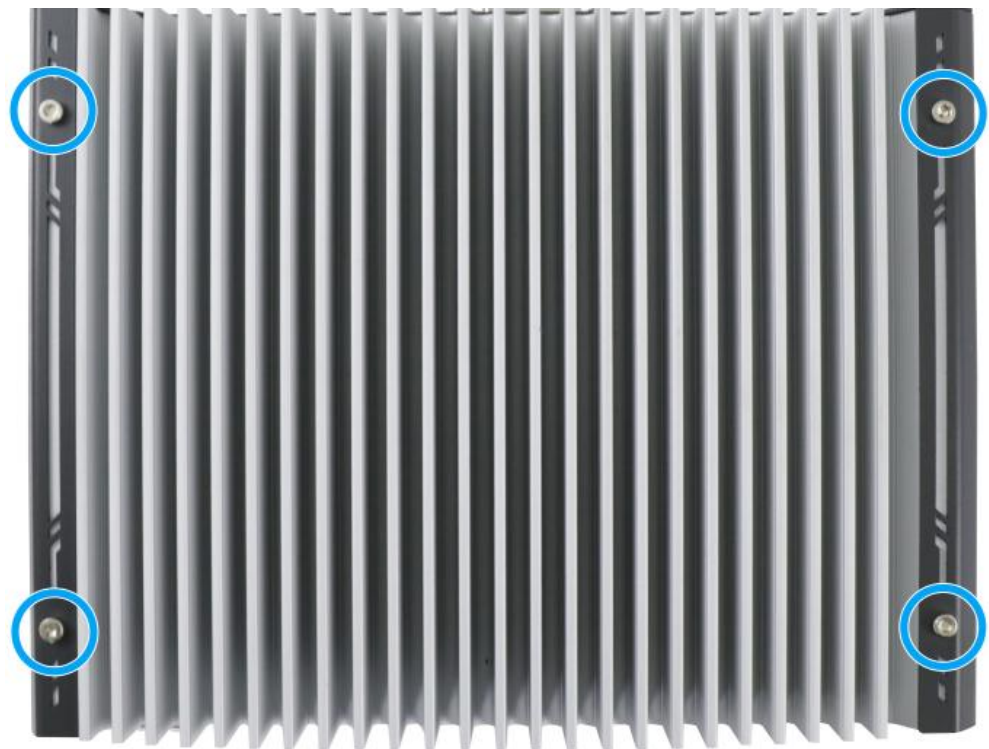

5. Gently separate the chassis' side walls to gain access to the system's internal expansion slots, DRAM socket, etc.



3.2 Disassembling Nuvo-9531-FT

To access Nuvo-9531-FT internal components, the enclosure needs to be disassembled. To disassemble the system enclosure, please refer to the procedures below

1. Place the system on a flat surface, and remove the screws indicated on the flattop heatsink contact side.



2. Turn the system up-side down, remove the screws indicated.

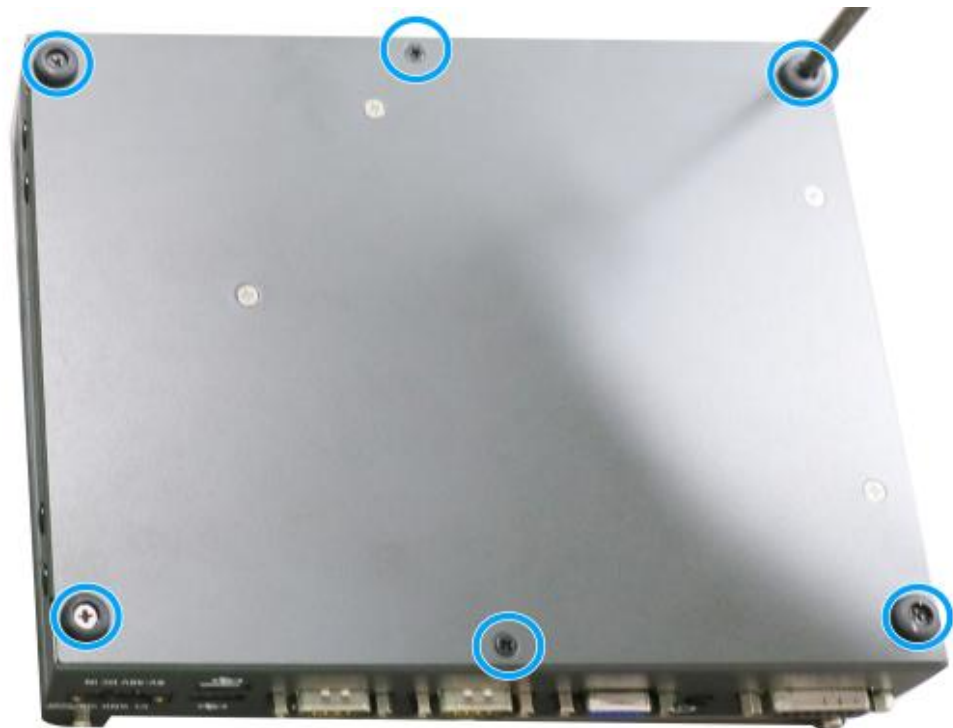

3. Remove the bottom panel.



4. Remove the hex-bolt screw.



5. Gently separate the enclosure from the flattop heatsink.



6. Remove the hex-bolt screws indicated on the COM port panel.



7. Remove the COM port panel.



8. You now have access to the system's internal expansion slots, DRAM socket, etc.

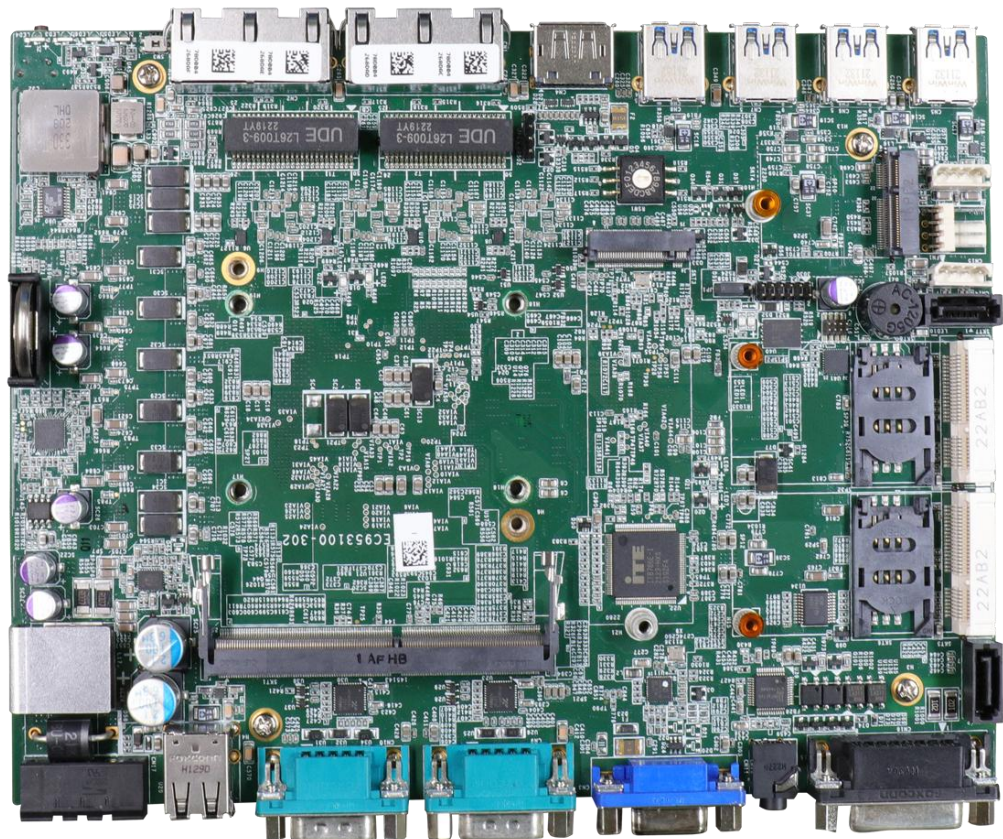

3.3 Installing Internal Components

3.3.1 CPU Installation for Barebone System

1. To install the CPU, you will need to separate the heatsink and the motherboard.
2. To do so, remove the four screws indicated below.

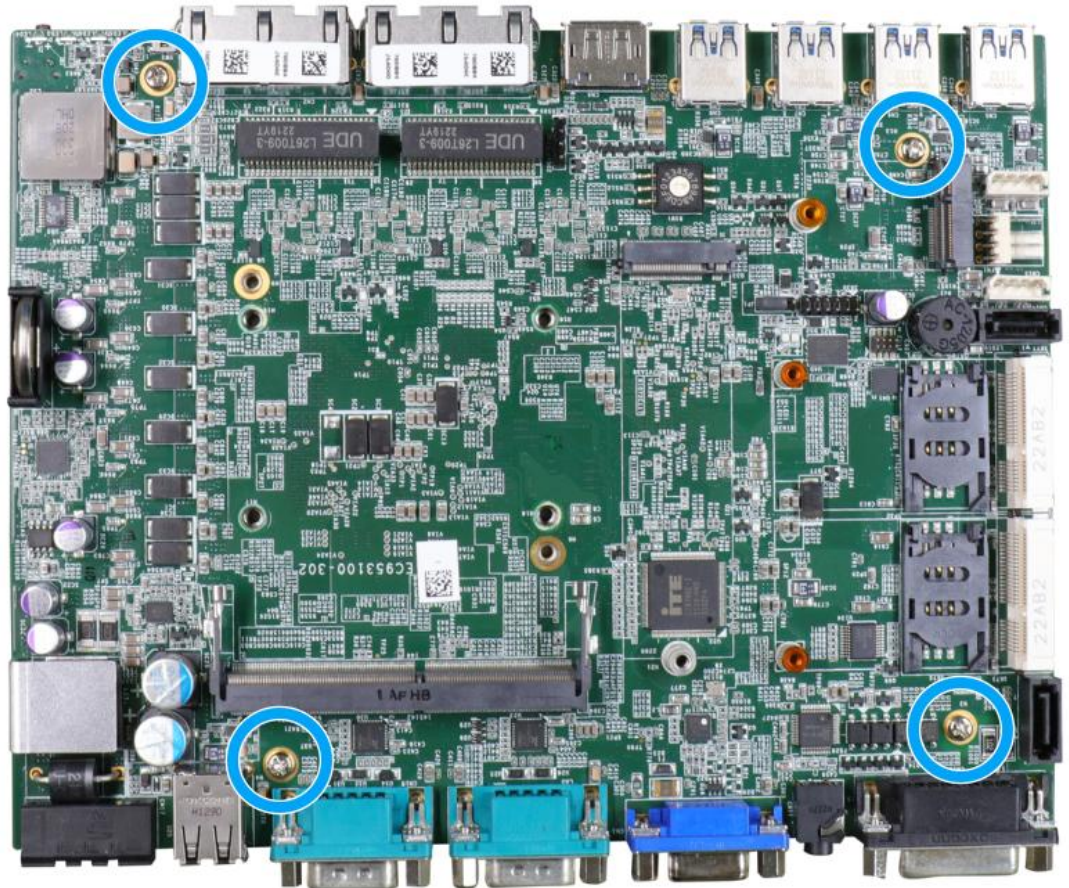

3. Gently separate the motherboard from the heatsink, you'll see the CPU socket protective cover, gently lift the cover.

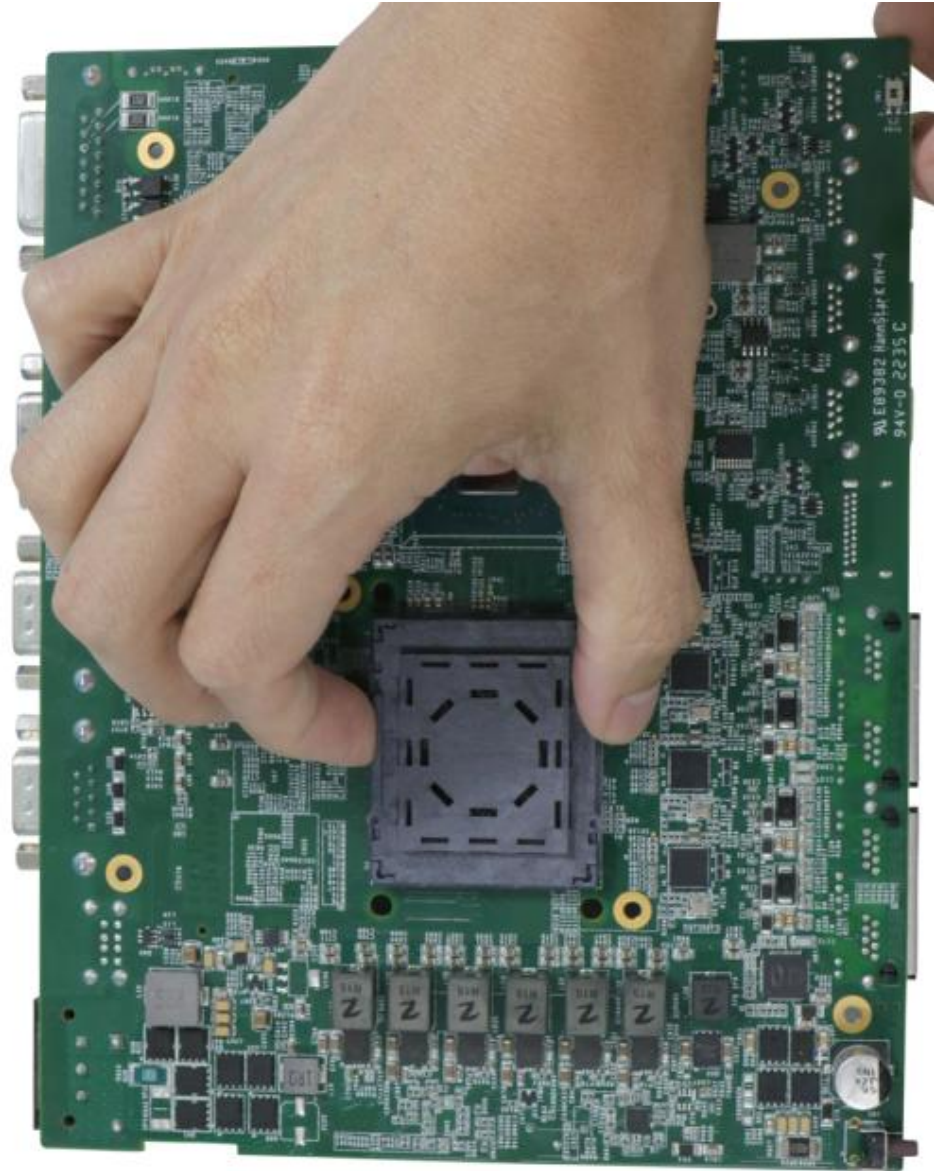

 **WARNING**

*With the protective cover removed, please be careful when handling the motherboard.
DO NOT touch the pins in the LGA socket!*

- Remove the CPU from its container/ tray. Match the four notches on the side (indicated by the **blue arrows**) to the protrusions in the socket, gently lower the CPU into the socket. Pay attention to the seating orientation, notice there is a short side (indicated by **green lines**), and a long side (indicated by **red lines**).



- Locate the CPU retention bracket (holder) from the accessory box. Place the retention bracket on the CPU and hold it in place. Make sure the indicator triangle engraved on the CPU's integrated heat spreader (HIS) and the triangle indicator on the retention bracket are positioned in the same corner (indicated by **blue circles**).

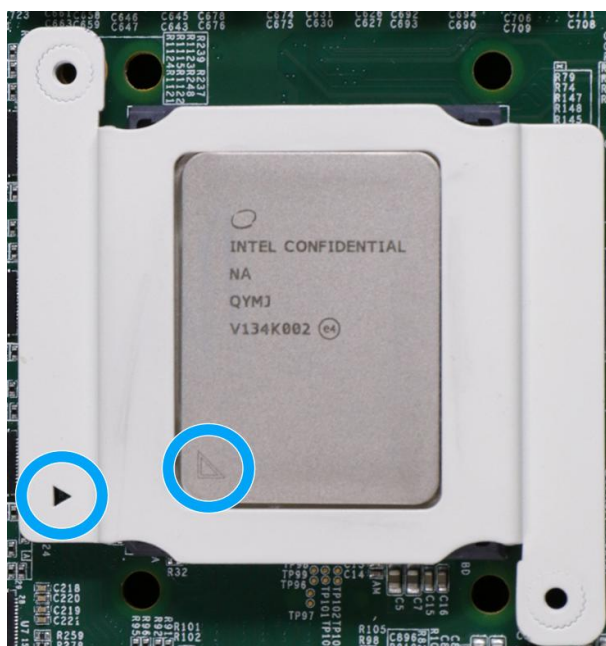

- Turn the motherboard around while holding the CPU retention bracket in-place, and secure the bracket by tightening two M3 P-head screws on the other side of the motherboard.

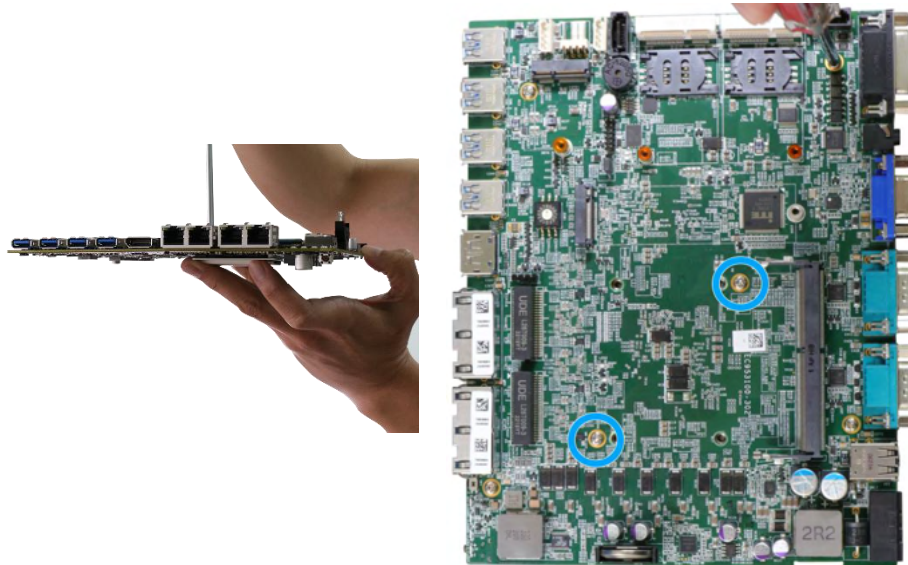

Hold CPU bracket firmly and turn the motherboard around

Secure two M3 P-head screws

- Make sure all thermal pad's protective films on the heatsink are removed.

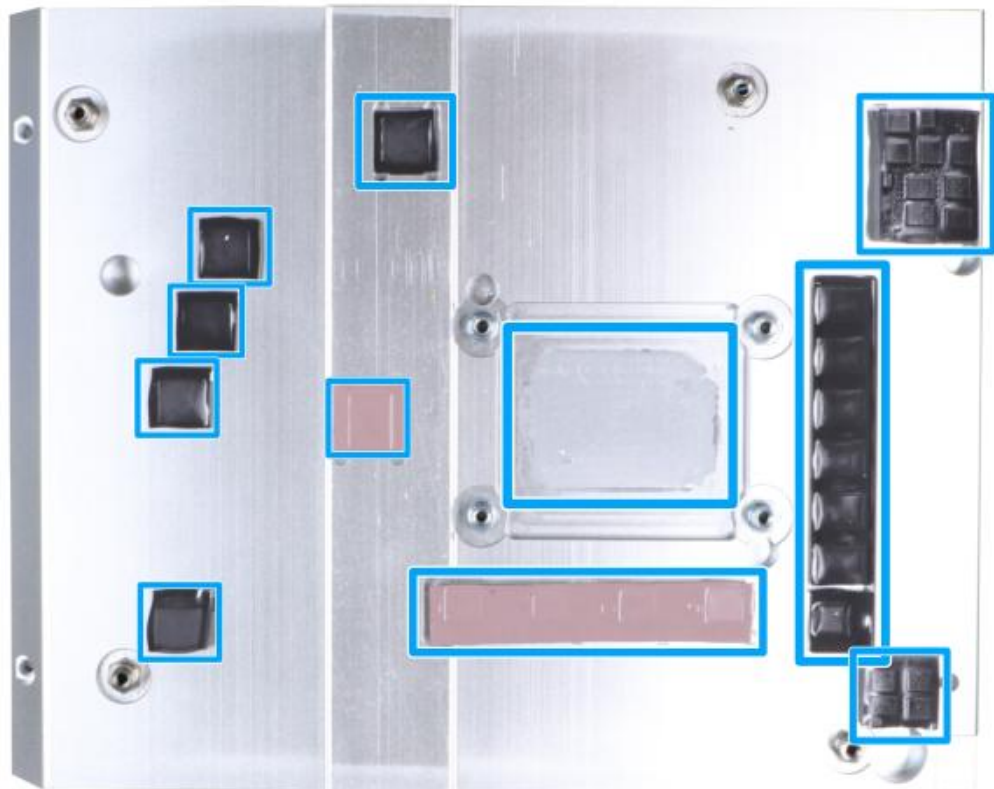

8. With the four motherboard standoffs aligned, gently lower the motherboard onto the heatsink and secure the four screws.

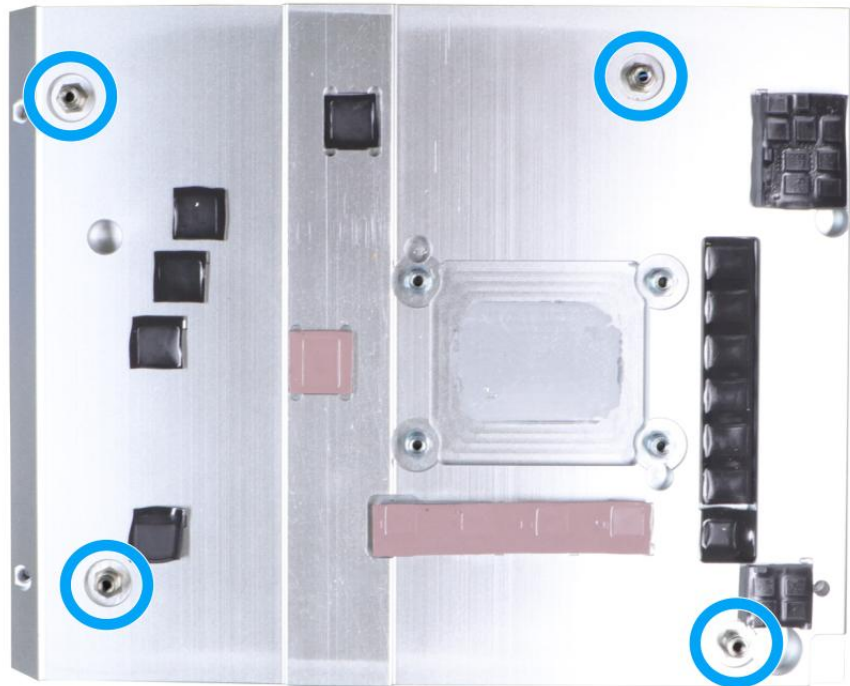

Four standoffs on the heatsink

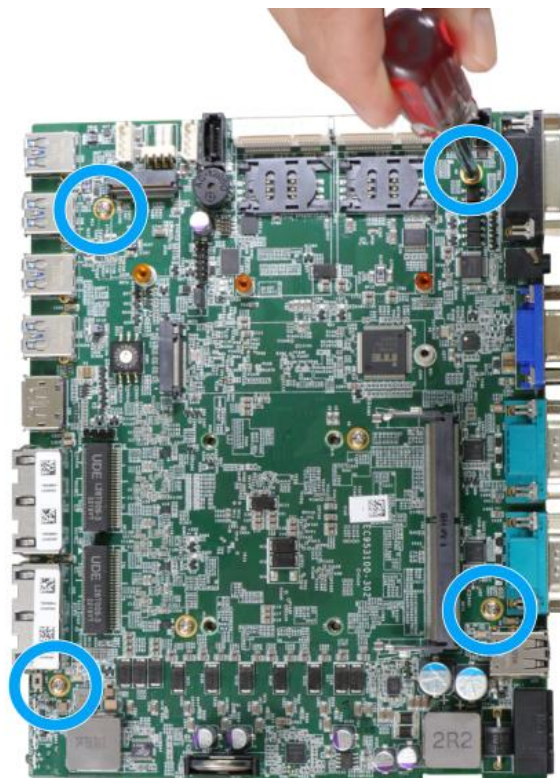

Secure motherboard with four screws

9. Once the motherboard has been installed, you're ready to secure the four screws that help the heatsink apply pressure to the CPU/ chipset die. You'll want to apply even pressure to the corners by gradually tightening each screw. Please refer to the recommended order when tightening the screws.

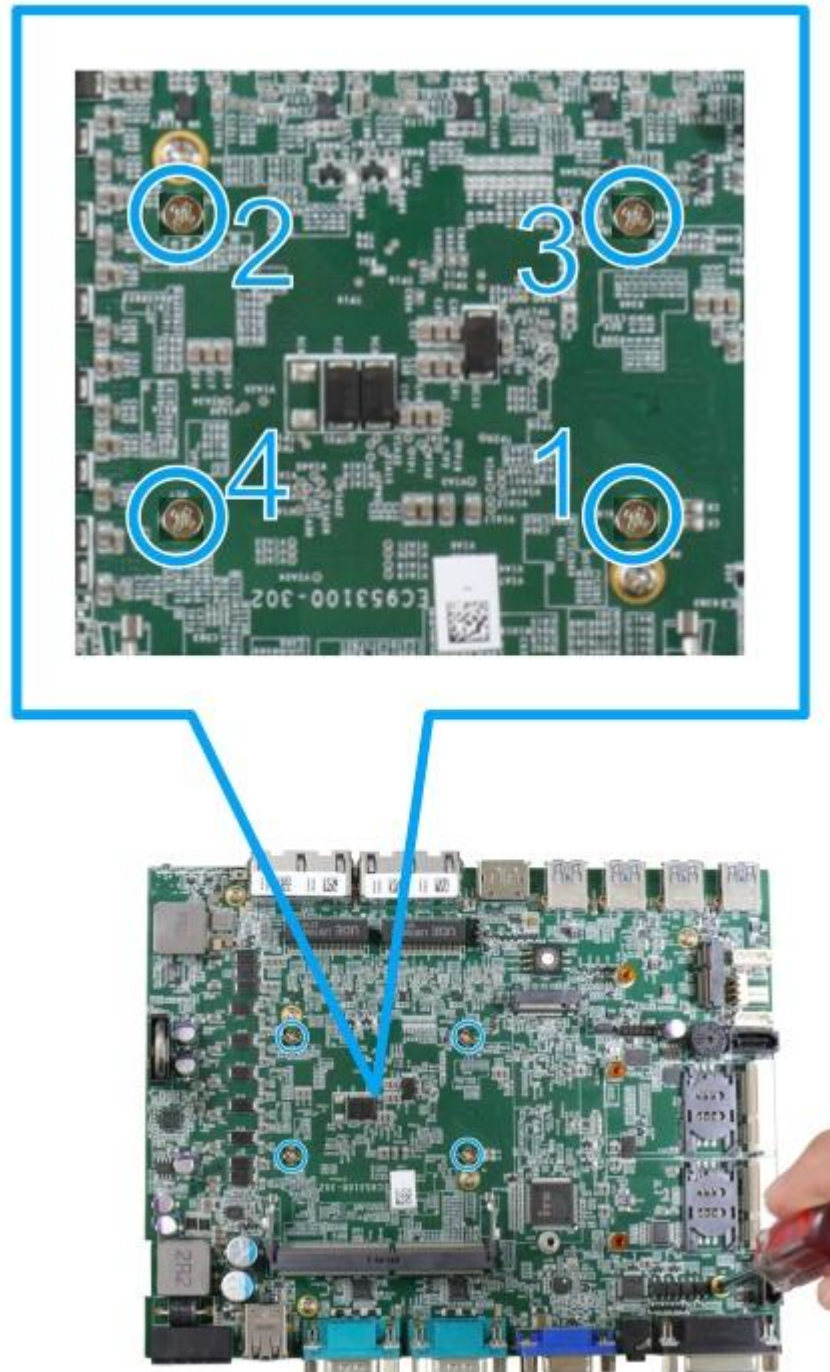

10. [Reinstall the system enclosure](#) and panel when done.

If you need to install other components, please refer to respective sections.

3.3.2 Remove the Replace the Existing CPU

1. To replace the existing CPU, you will need to separate the heatsink and the motherboard.
2. To do so, remove the eight screws indicated below.

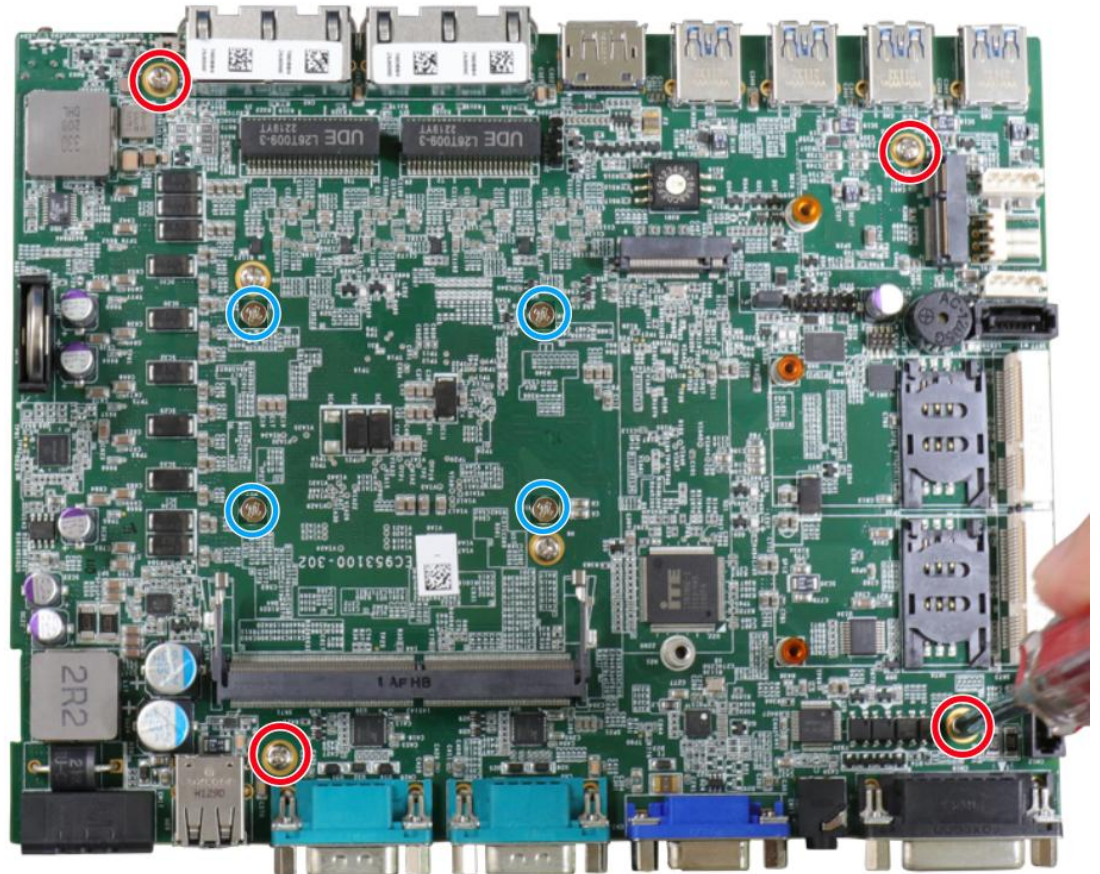

3. Remove the screws indicated once you separate the heatsink from the motherboard to remove the CPU holder.

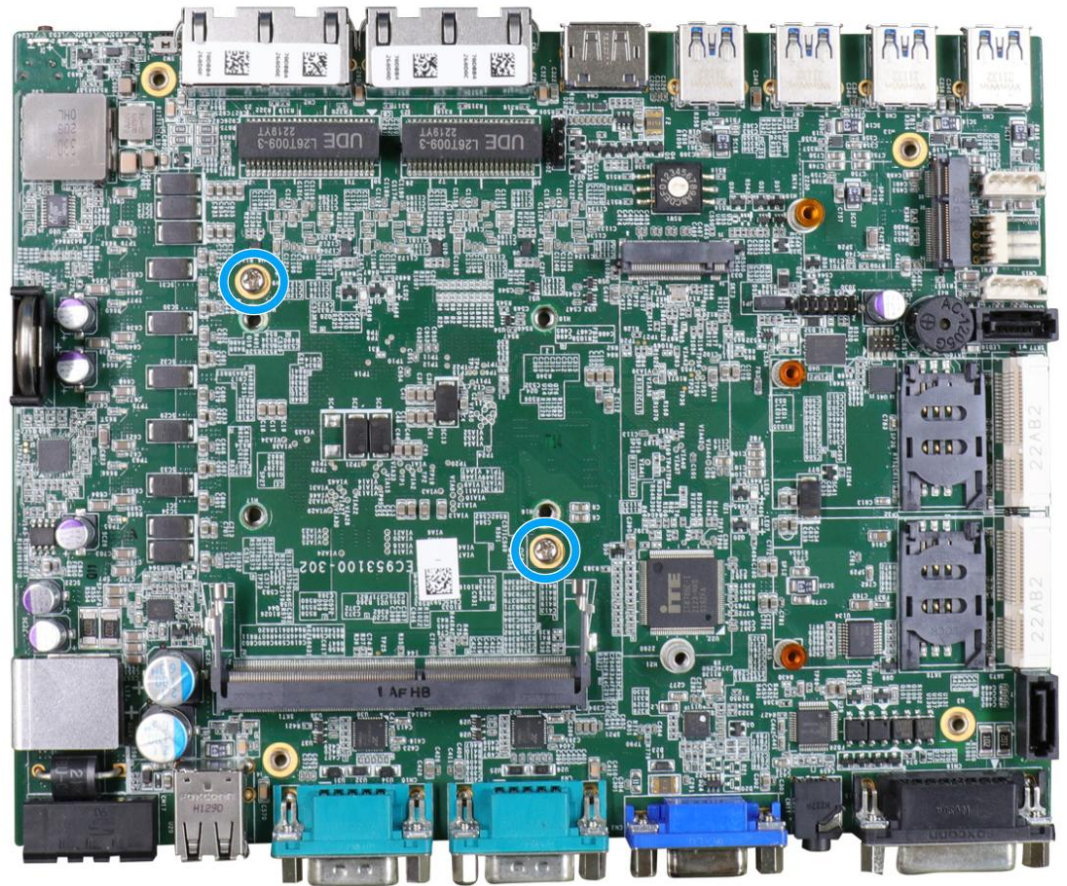

4. At this point, the CPU and retention bracket may be stuck onto the heatsink (due to the thermal pad). Please use a plastic pry tool to gently separate the CPU/ holder from the heatsink, and clean off any thermal pad residues on the retention bracket.

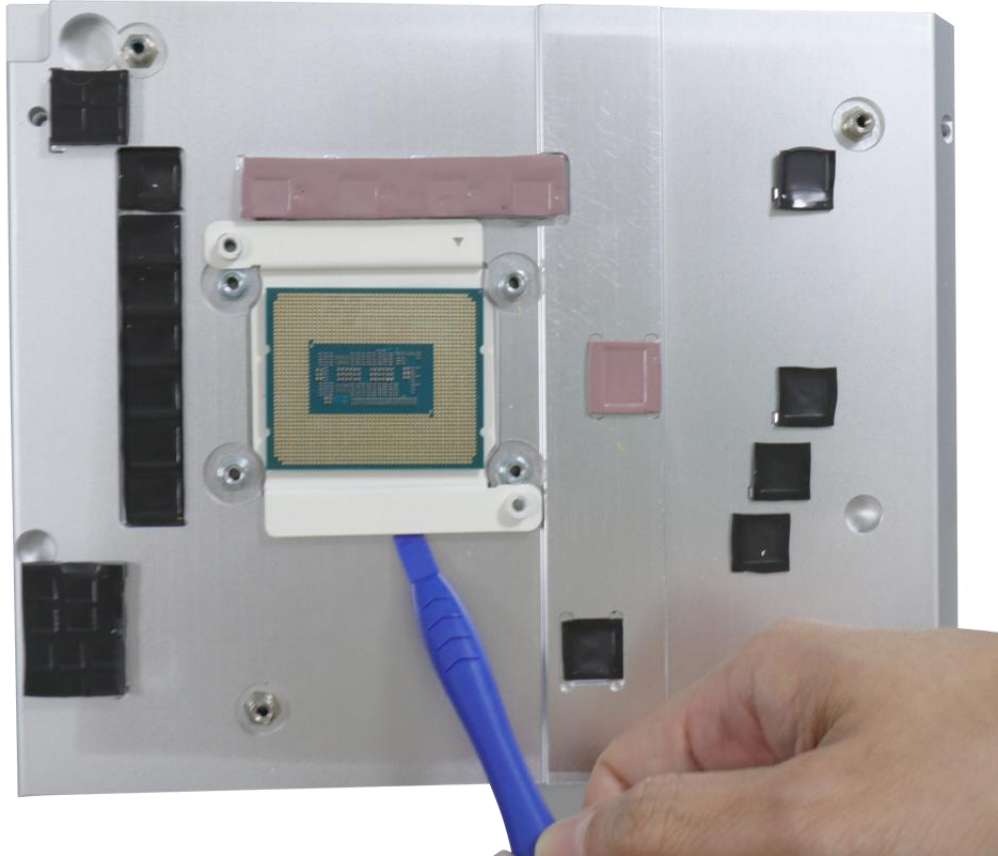

 **WARNING**

With the heatsink, CPU, and retention bracket removed, please be careful when handling the motherboard. DO NOT touch the pins in the LGA socket!

5. Place a new CPU thermal pad (indicated in blue) onto the heatsink for the new CPU.

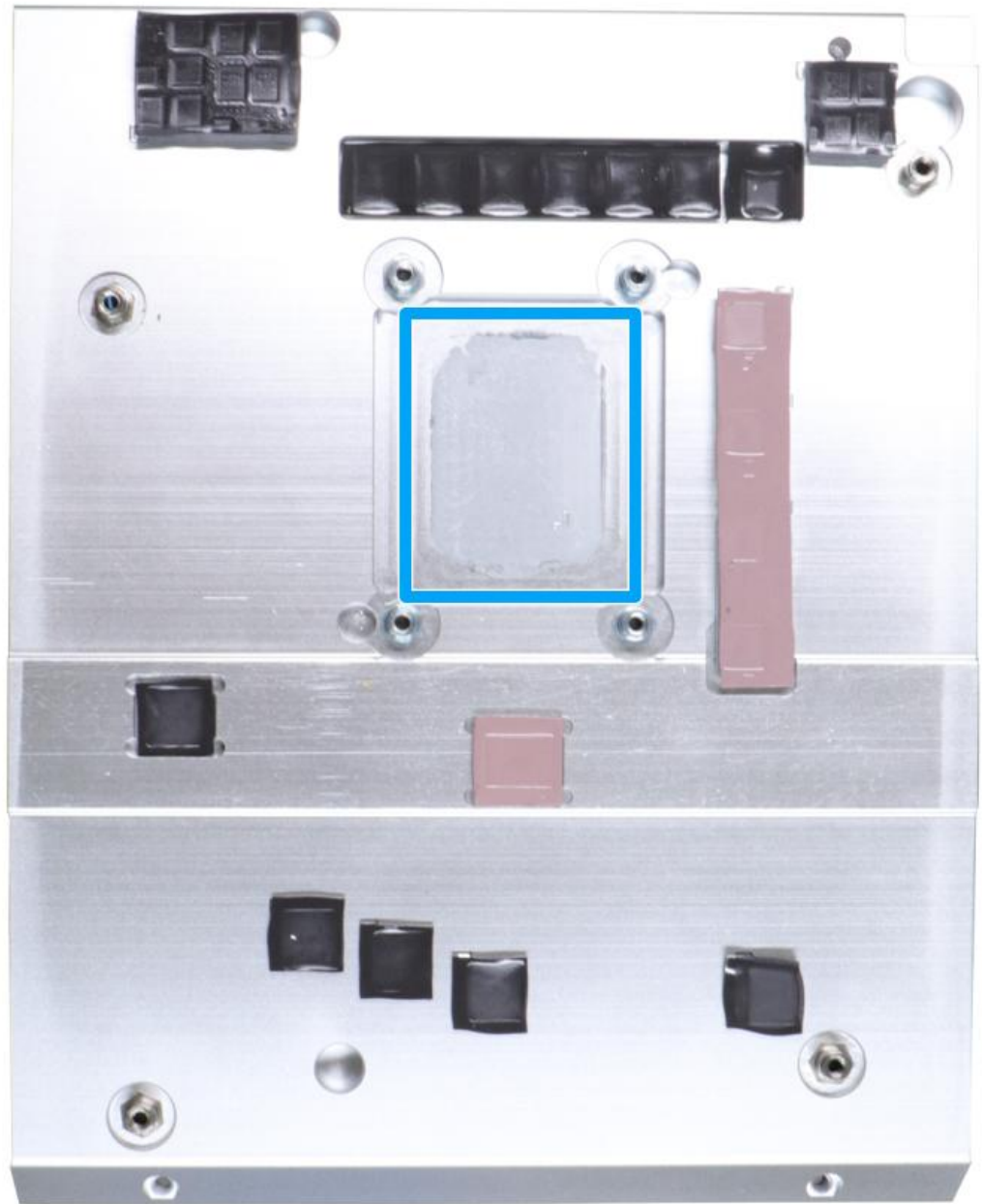

- Remove and clean off any thermal pad residues around the socket/ motherboard. Gently place the new CPU into the socket by matching the four notches (indicated by **blues arrows**) on the side to the protrusions in the socket. Pay attention to the seating orientation, notice there is a short side (indicated by **green lines**), and a long side (indicated by **red lines**).



- Make sure all thermal pad residues have been cleaned on both sides of the retention bracket. Place the CPU retention bracket (holder) on top of the CPU and hold it in place. Make sure the indicator triangle engraved on the CPU's integrated heat spreader (HIS) and the triangle indicator on the retention bracket are positioned in the same corner (indicated by **blue circles**).

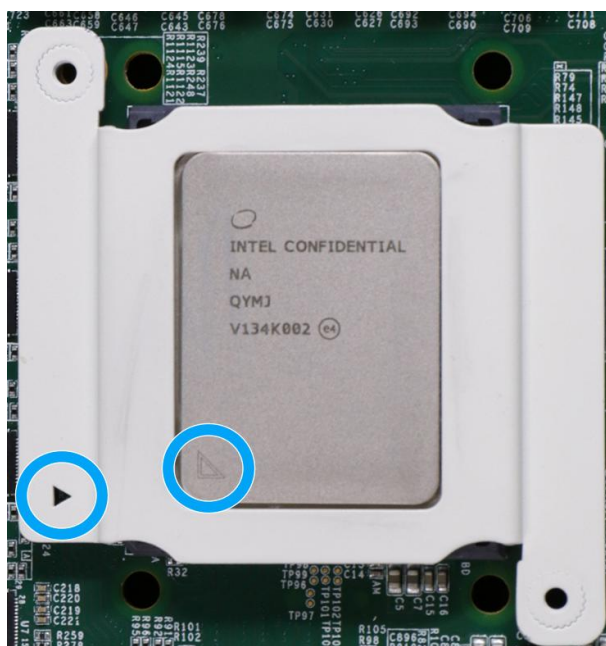

8. Turn the motherboard around and secure the bracket by tightening two M3 P-head screws.

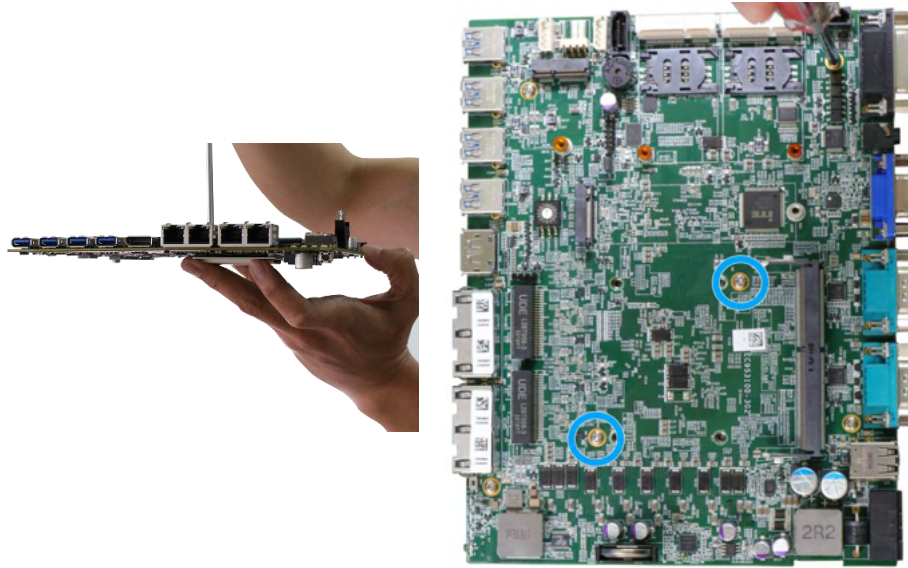

Hold CPU bracket firmly and turn the motherboard around

Secure two M3 P-head screws

9. Align the motherboard to the four standoffs on the heatsink, gently lower the motherboard onto the heatsink and secure with four screws.

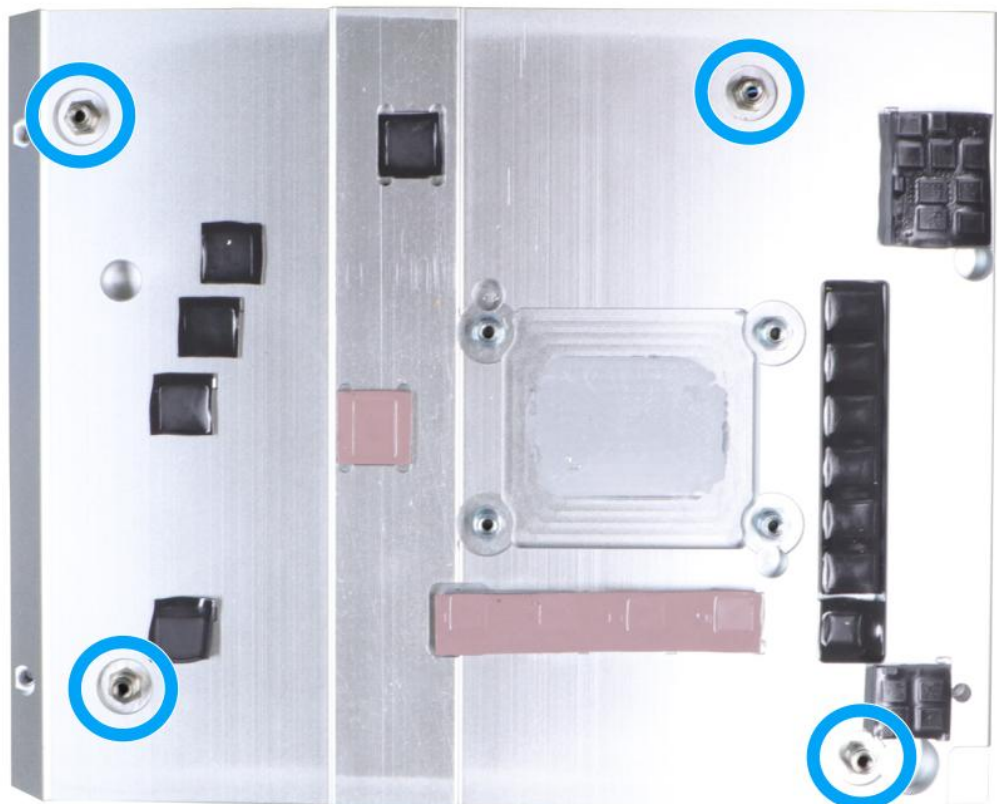

- Once the motherboard has been installed, you're ready to secure the four screws that help the heatsink apply pressure to the CPU/ chipset die. You'll want to apply even pressure to the corners by gradually tightening each screw. Please refer to the recommended order when tightening the screws.

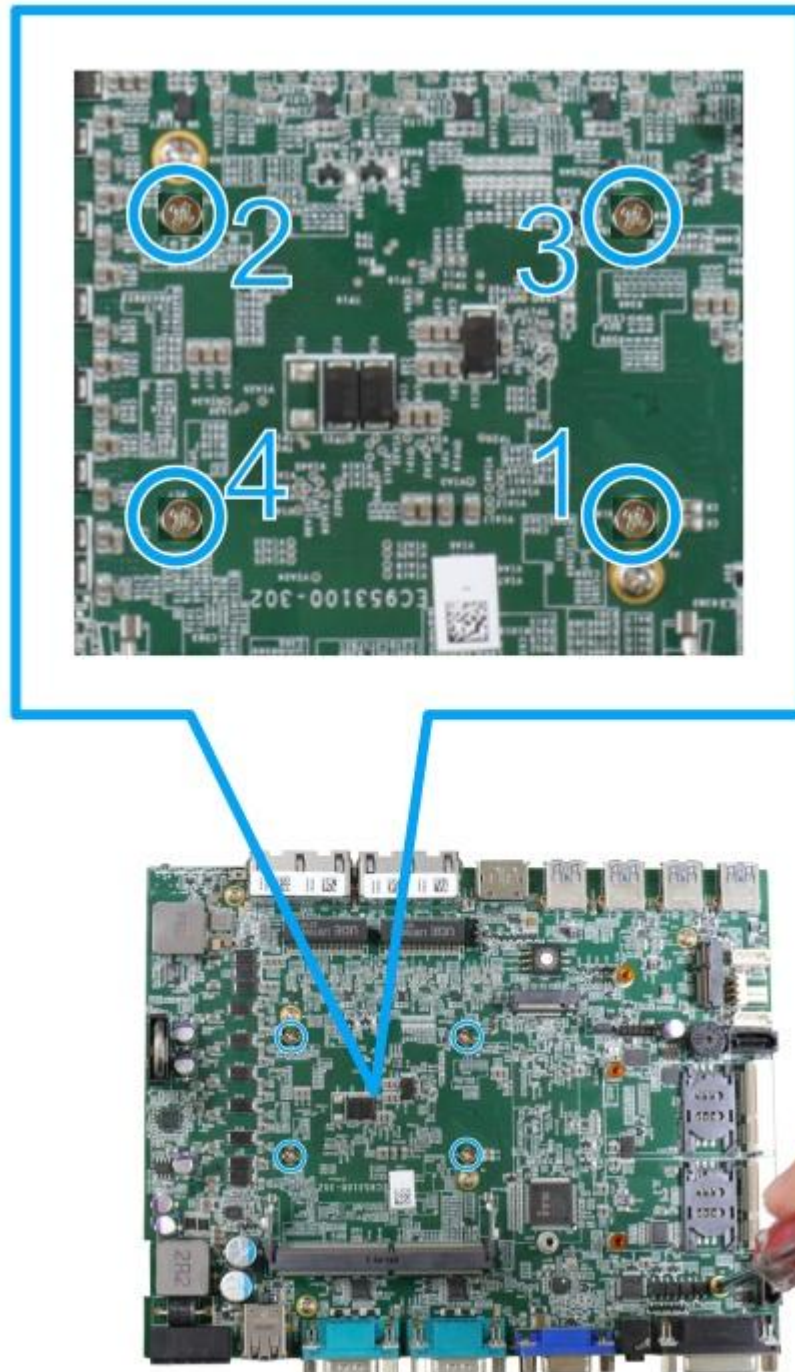

- Reinstall the system panels, enclosure, and Cassette module when done.
If you need to install other components, please refer to respective sections

3.3.3 DDR4 SO-DIMM Installation

There is a single memory SO-DIMM slot on the motherboard that supports up to 32GB DDR4-3200. Please follow the procedures below to replace or install the memory modules.

1. Please refer to the section “[Disassembling the System](#)”, you may not need to completely dismantle the system to gain access to the memory module slots.
2. Locate the SODIMM memory module slot on the motherboard.

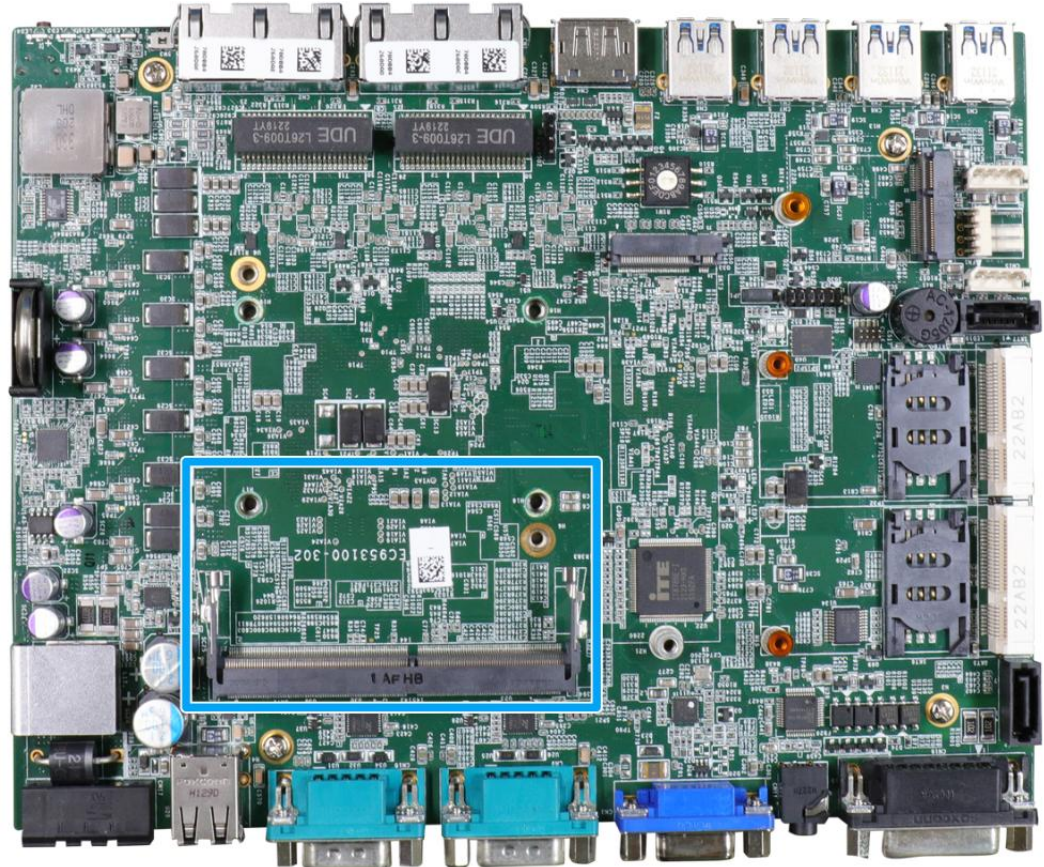

3. To install the memory module, insert gold fingers of the module into the slot at 45 degree angle, push down on the edge of the module and the clips on the side should clip the module into position.



4. Push the memory module down until it is clipped-in.



5. If you are installing the DRAM module for the first time, please remove the thermal pad protective film attached to the bottom of the hot-swappable tray enclosure.

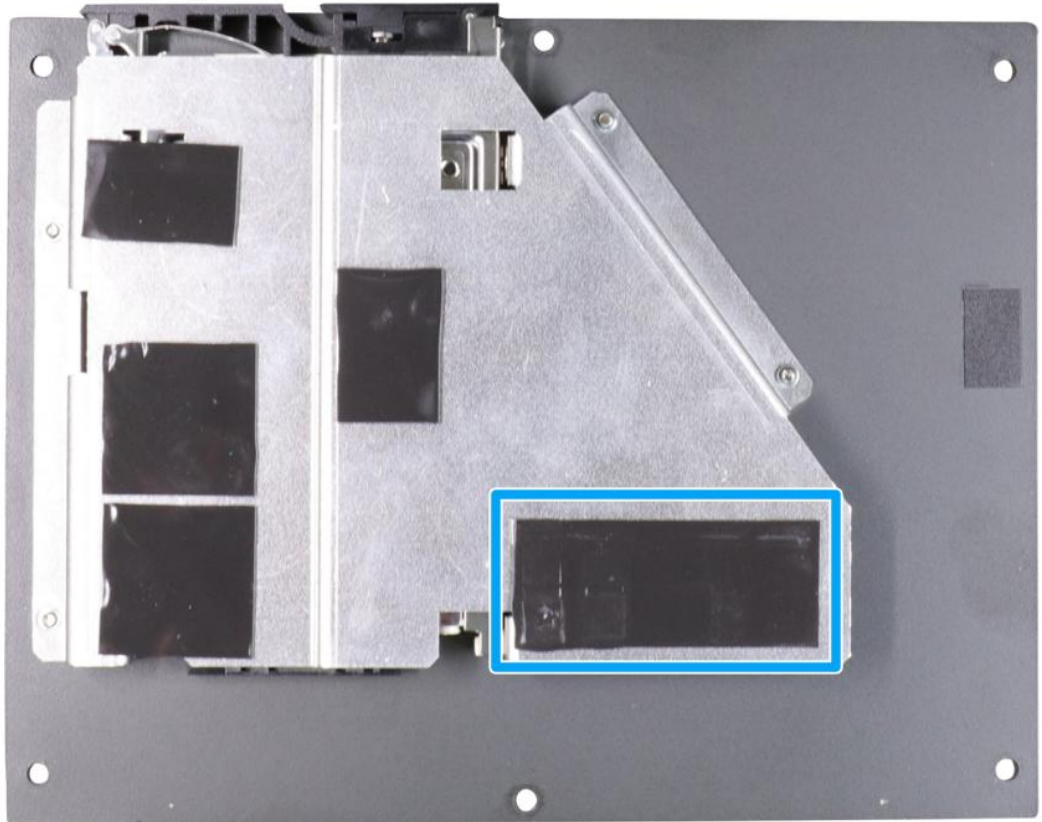

6. [Reinstall the system enclosure](#) and panel when done.

If you need to install other components, please refer to respective sections.

3.3.4 M.2 2280 SSD Installation

The system has a Gen4 x4 PCIe M.2 2280 slot for you to install an NVMe SSD. For installation, please refer to the following instructions.

1. Please refer to the section "[Disassembling the System](#)", you may not need to completely dismantle the system to gain access to the expansion slot.
2. Locate the M.2 2280 slot on the motherboard.

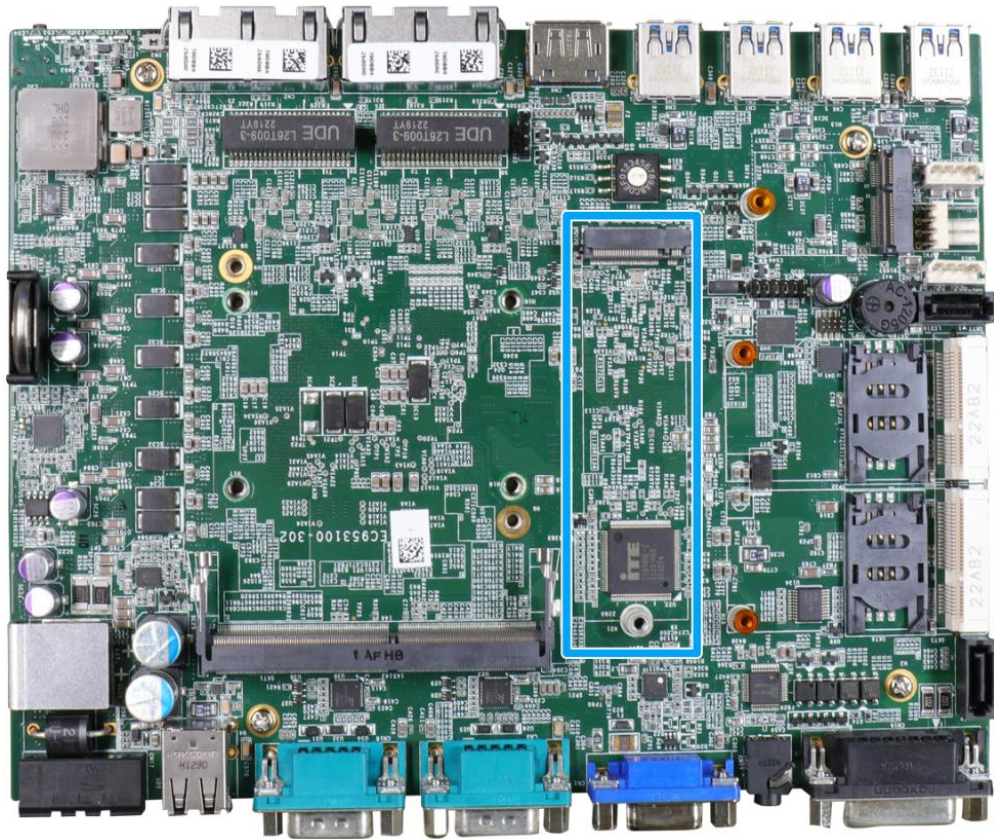

3. Insert the module on a 45 degree angle.



4. Gently press down and secure the module with an M3 P-head screw.



5. If you are installing the M.2 2280 module for the first time, please remove the thermal pad protective film attached to the bottom of the hot-swappable tray enclosure.

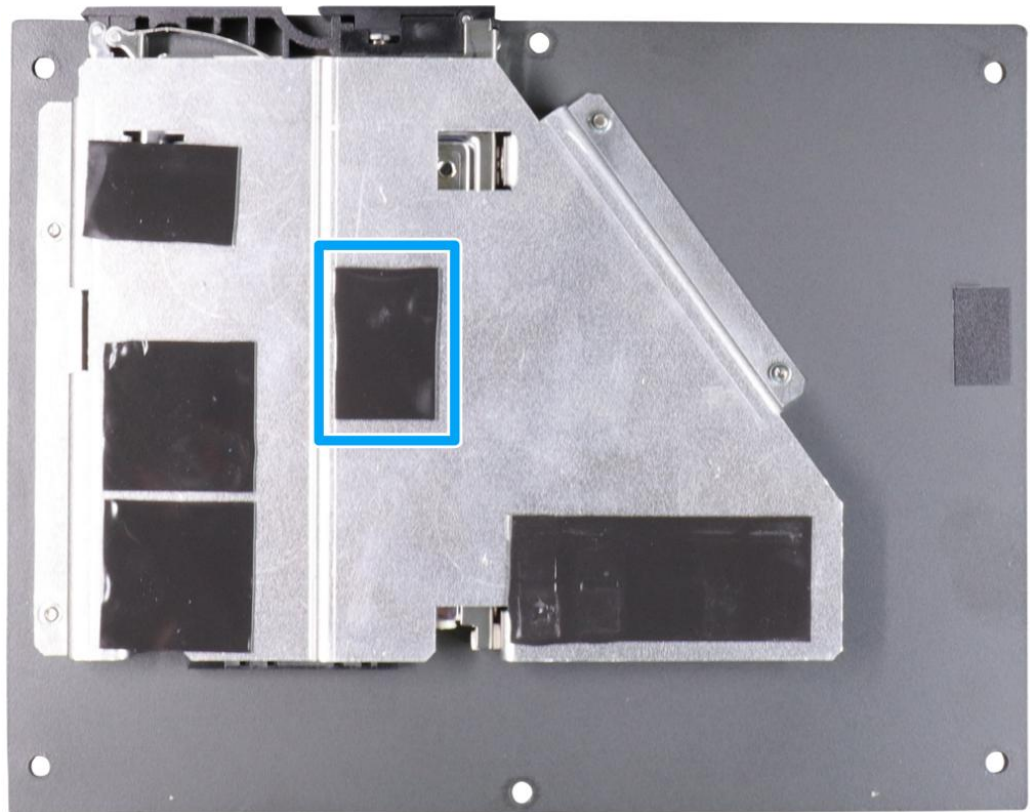

6. [Reinstall the system enclosure](#) or the trapdoor when done.
7. If you need to install other components, please refer to respective sections.

3.3.5 mini-PCle Module Installation

The system has two mini-PCle slots. To install a mini-PCle module, please refer to the following instructions.

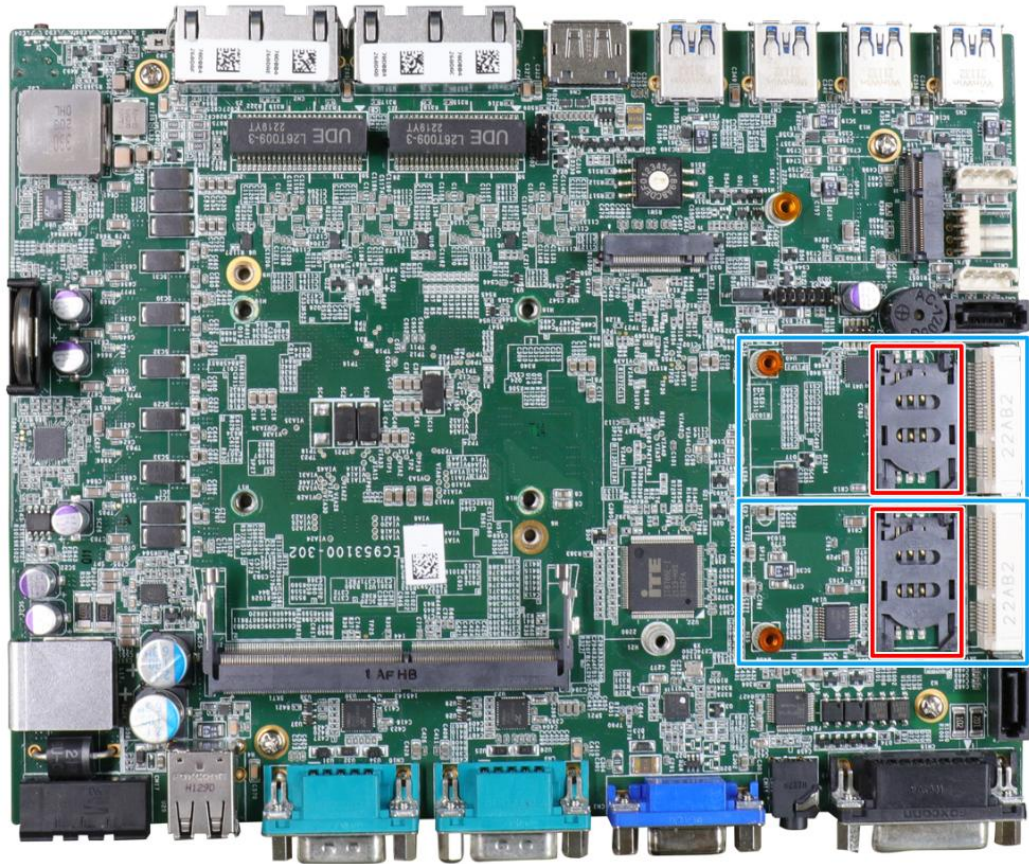

1. Please refer to the section [“Disassembling the System”](#), you may not need to completely dismantle the system to gain access to the expansion slot.
2. Locate the mini-PCle slots (indicated in **blue**) and their corresponding SIM card slots (indicated in **red**). Insert the corresponding SIM card before you install the mini-PCle module.

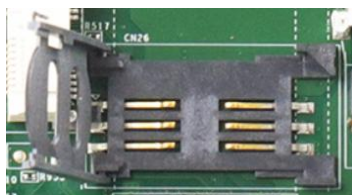

Slide and lift SIM card holder



Insert SIM card with pins facing up



Secure the SIM card by sliding the holder

3. Insert the mPCIe module on a 45 degree angle into the mPCIe slot and secure the module.

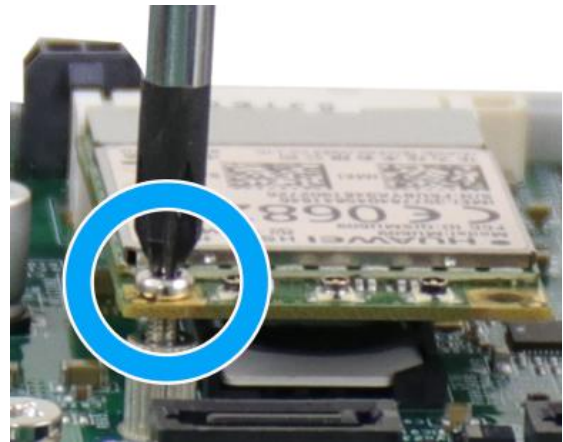

Insert on 45 degree angle

Secure the module

4. Clip on the IPEX-to-SMA cable to the module and secure the antenna to the side panel. Please refer to the module's manual for clip-on connection.
5. Secure antenna body to side panel

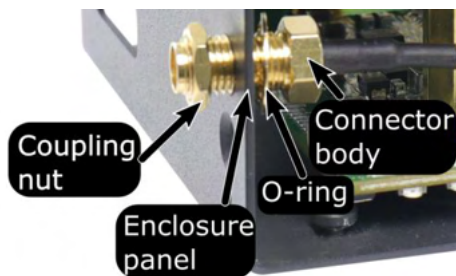

Secure on side panel

6. If you are installing the mini-PCIe module for the first time, please remove the thermal pad protective film attached to the bottom of the hot-swappable tray enclosure.

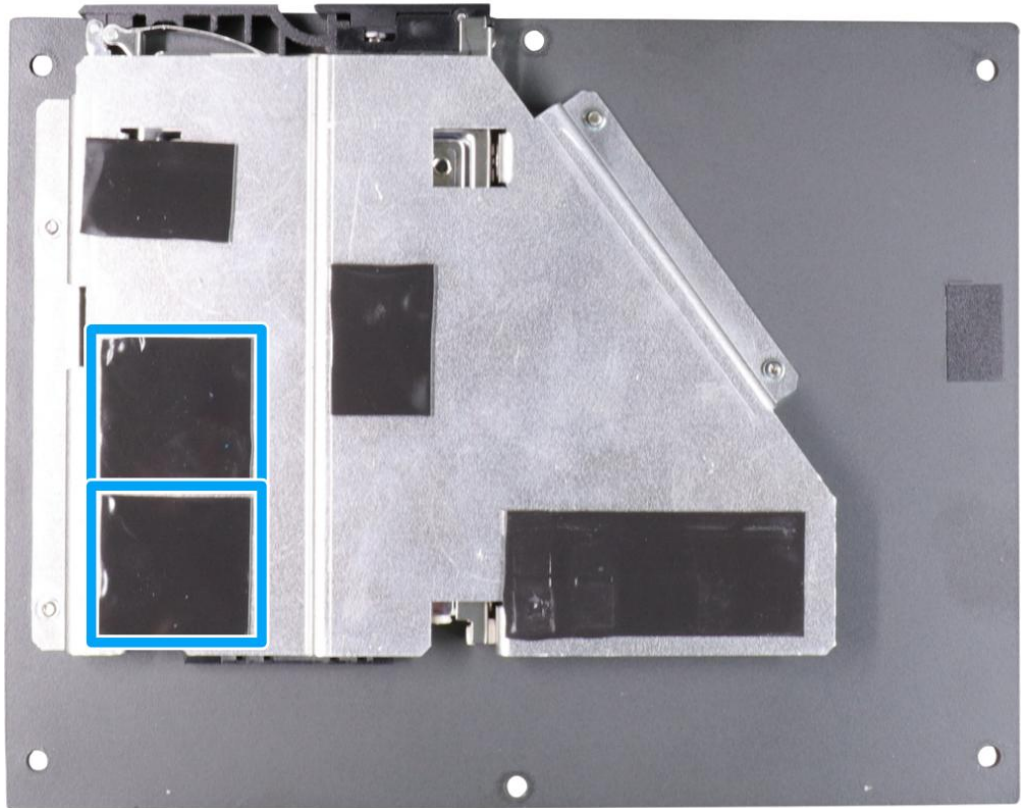

7. [Reinstall the system enclosure](#), and attached the external antenna to the side of the panel.



If you need to install other components, please refer to respective sections.

3.3.6 M.2 2230 E Key Module Installation

The system has an M.2 2230 E key socket that offers PCIe Gen3 x1 and USB2.0 signal for WiFi 6/5 or Google TPU module installation. To install a M.2 2230 E key module, please refer to the following procedure:

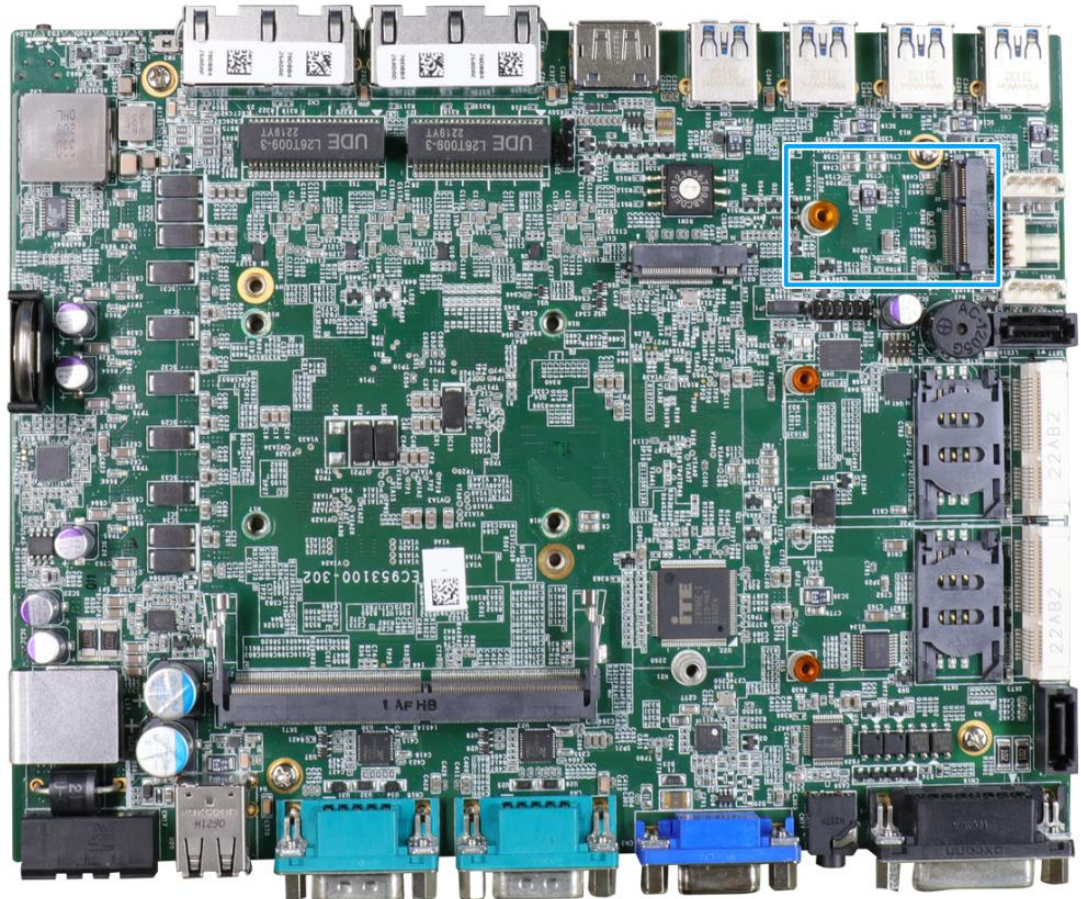

1. Please refer to the section “[Disassembling the System](#)”, you may not need to completely dismantle the system to gain access to the expansion slot.
2. Locate the M.2 2230 E key slot location (indicated in blue).
3. Insert the module on a 45 degree angle, gently press down and secure with a screw.



4. Clip on the IPEX-to-SMA cable to the module and secure the antenna to the side panel. Please refer to the module’s manual for clip-on connection.

- Secure antenna body to side panel

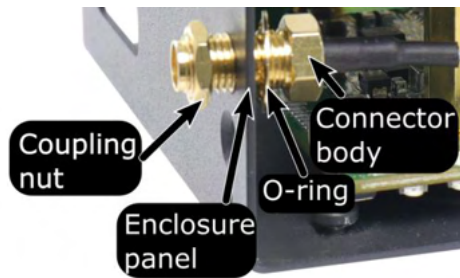

Secure on side panel

- If you are installing the M.2 2230 E key module for the first time, please remove the thermal pad protective film attached to the bottom of the hot-swappable tray enclosure.

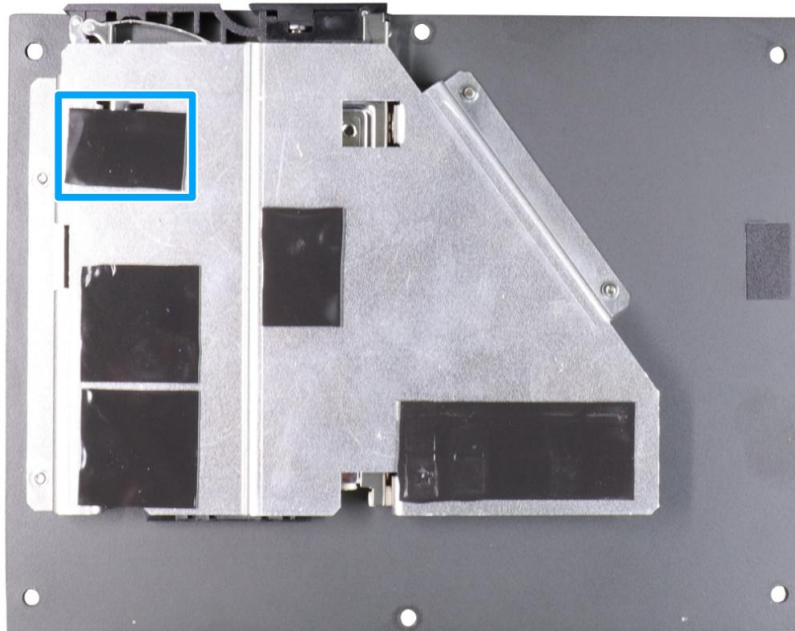

- [Reinstall the system enclosure](#), and attached the external antenna.



If you need to install other components, please refer to respective sections.

3.3.7 External Hot-swappable 2.5" HDD/ SSD Installation

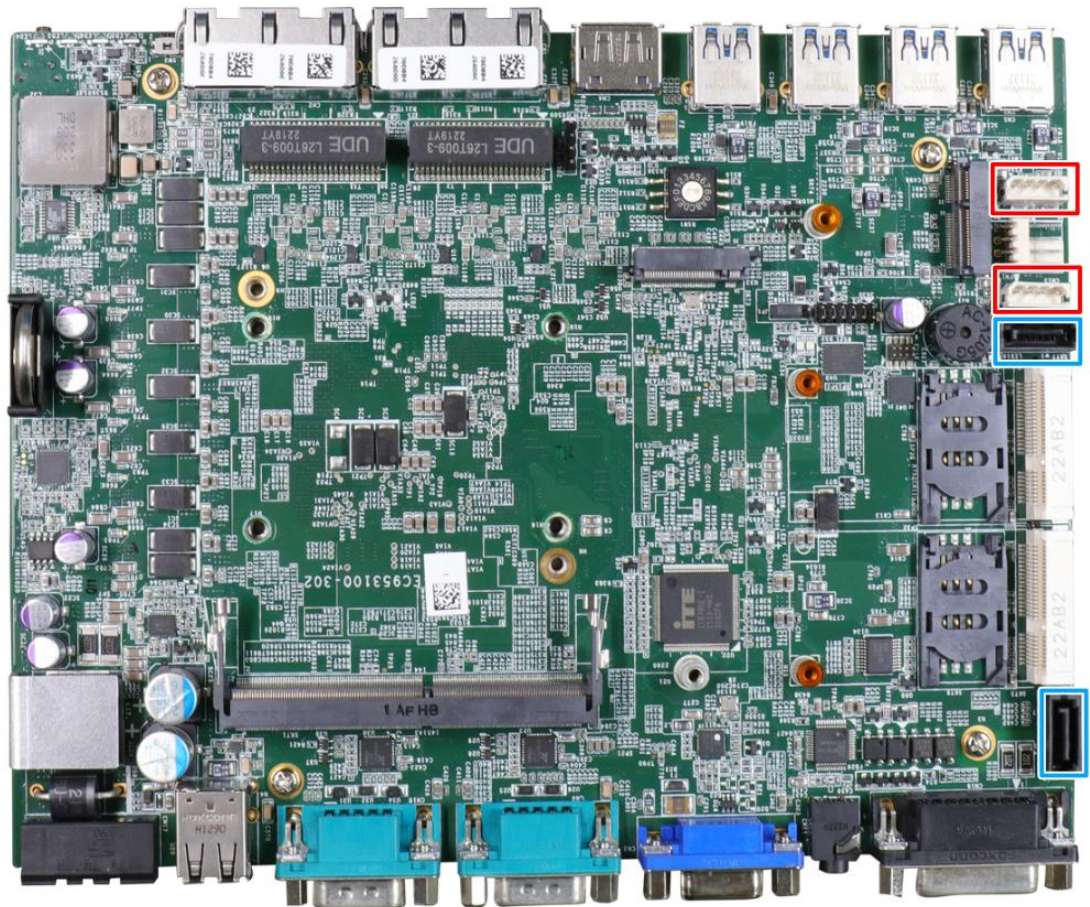

The system has two SATA ports (**blue**) and two four pin power connectors (**red**). The SATA and power cables should already be connected on the motherboard so users only need to install the 2.5" SATA HDDs/ SSDs to the front hot-swappable tray.

If you previously disconnected the SATA and power cables, please reconnect them before continuing this procedure.

1. Please refer to the section "[Disassembling the System](#)" to gain access to SATA port.

2. The SATA and power cable should already be connected to the hot-swappable tray situated on the bottom enclosure panel.

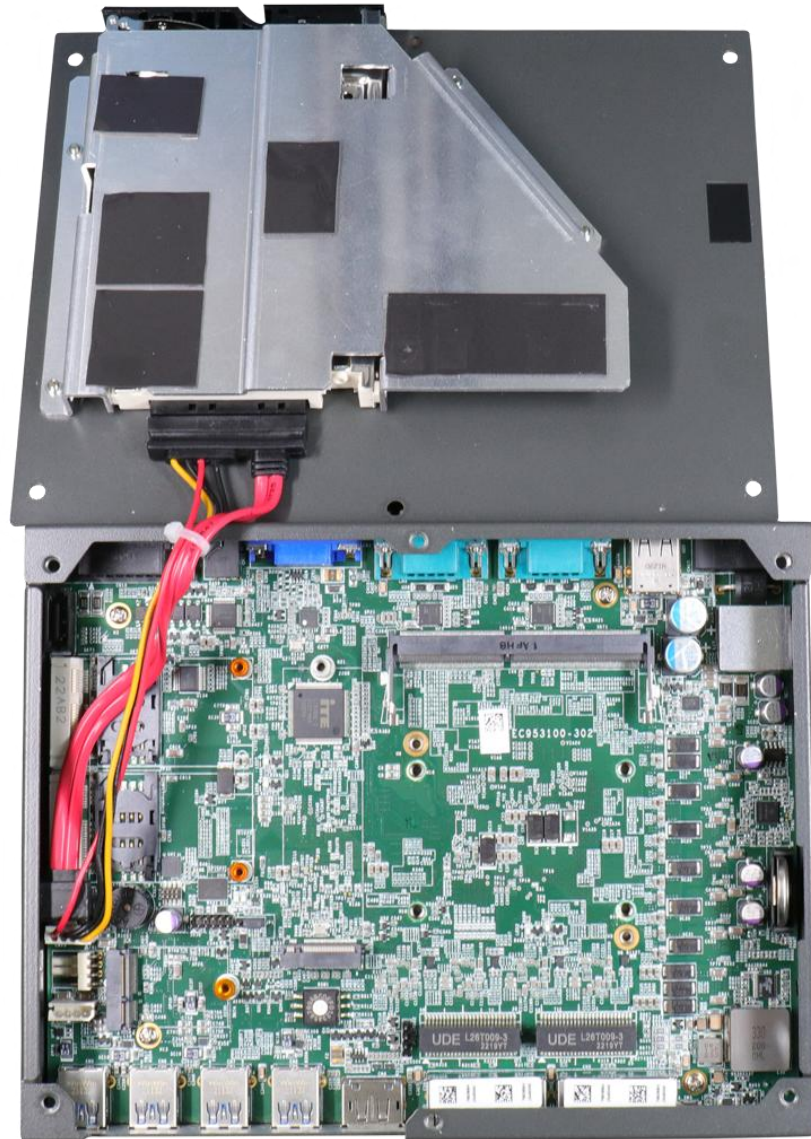

SATA/ power cables connected

3. Pull the lever on the 2.5" external hot-swappable slot to swing open the cover



- The tray supports a 7mm thickness HDD/ SSD. To install, with the label side facing upwards, insert the SATA connector side of the 2.5" HDD/ SSD into the slot first. You may feel resistance when the SATA connectors meet, push it in firmly until the 2.5" HDD/ SSD is fully inserted into the slot.



Insert HDD/ SSD into tray

- Push the lever into the 2.5" slot until it snaps into position. A key is provided (in accessory box) to lock the external slot.



Key in accessory box



2.5" HDD/ SSD slot lock

- [Reinstall the system enclosure](#) and panel when done.

If you need to install other components, please refer to respective sections.

3.4 Installing Nuvo-9531's Enclosure

To reinstall the system enclosure, please follow the steps below:

1. Slide the motherboard and heatsink back into the U-shaped enclosure and secure it with four screws on top of the heatsink.

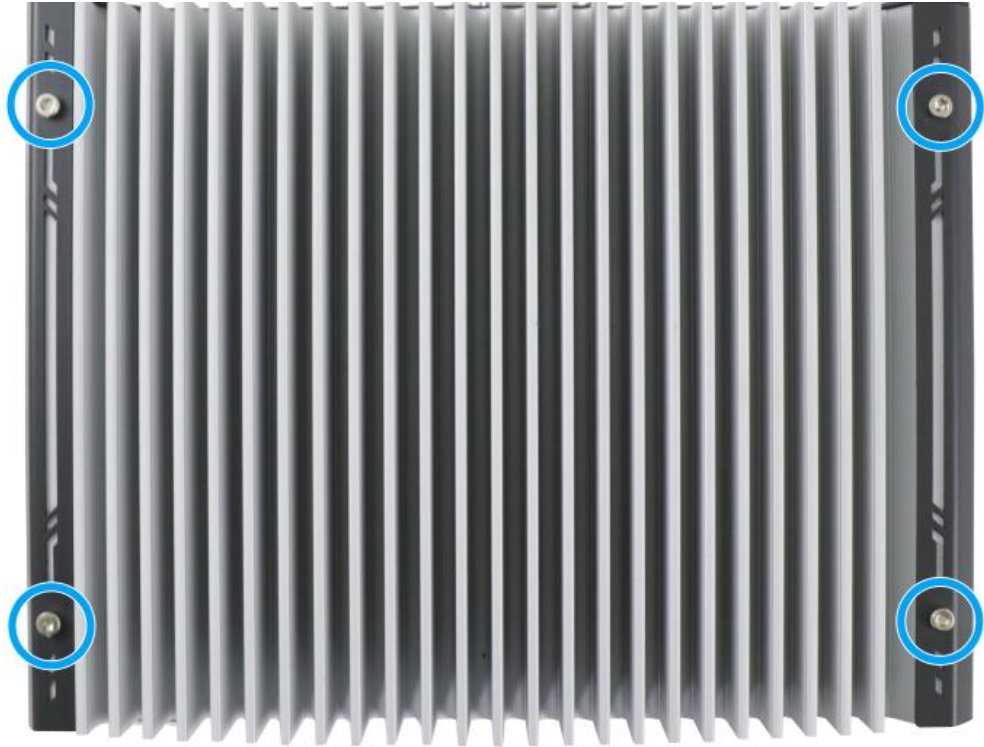

2. Secure the screw on the front I/O panel to the heatsink.



- Secure the three screws on the rear I/O panel to the heatsink.



- Secure the six screws at the bottom to complete enclosure installation process.

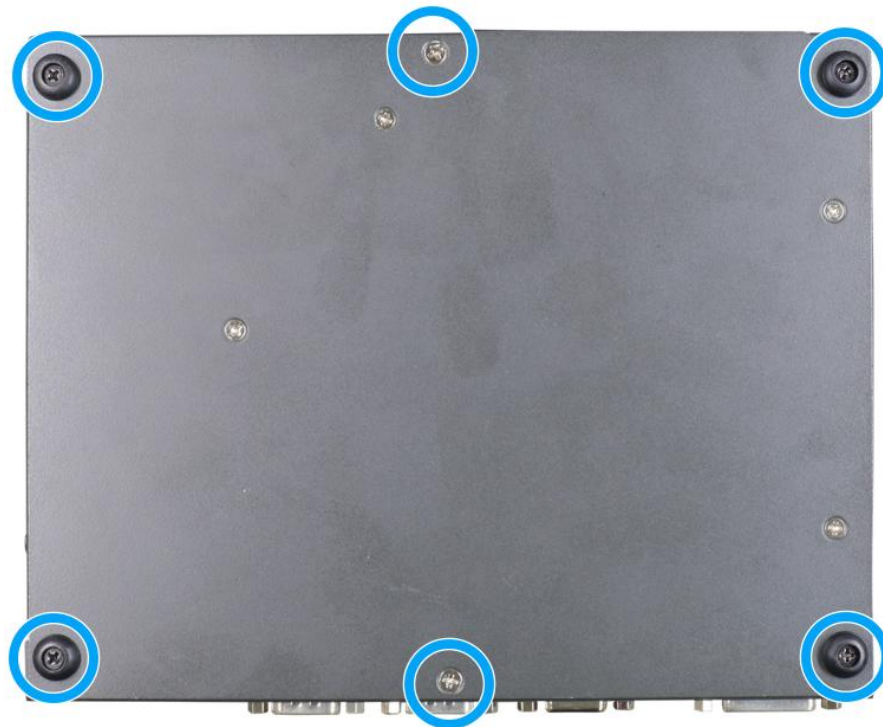

3.5 Installing Nuvo-9531-FT's Enclosure

To reinstall the system enclosure, please follow the steps below:

1. Install the COM port panel by securing the screws indicated.



2. Slide and fit the side enclosure onto the flattop heatsink.



- Secure the screws indicated to secure the Ethernet and side panel to the flattop heatsink.



- Connect the SATA cable to the 2.5" HDD/ SSD, if a HDD/ SSD is installed.



5. Gently place the bottom panel onto the enclosure and secure the screws indicated at the bottom to complete enclosure installation process.

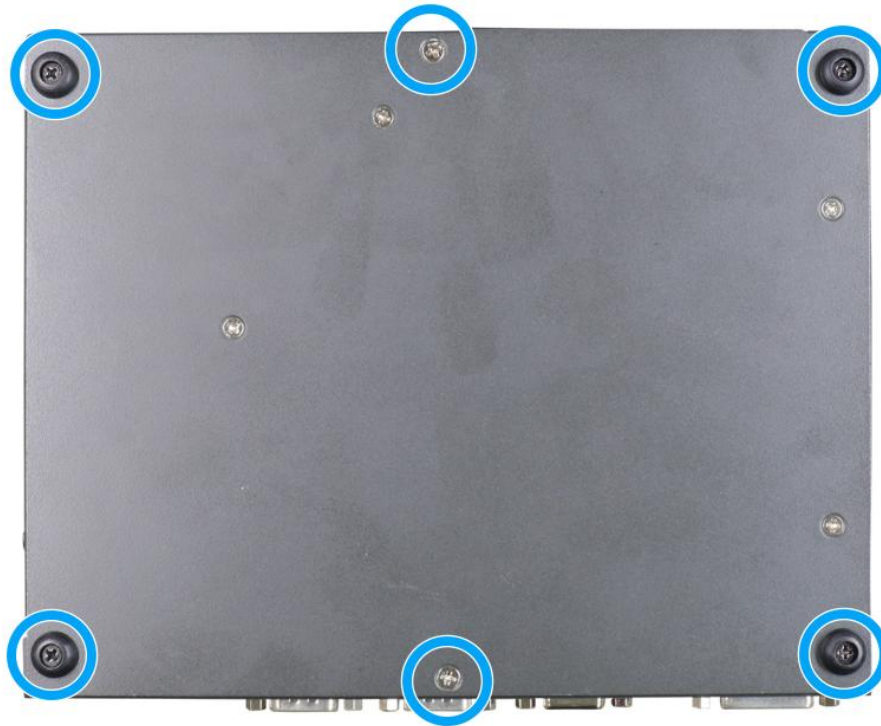

3.6 Ethernet/ PoE+ Port Panel Screw Fix

The system's RJ45 Ethernet ports (indicated in **blue**) have panel screw fix holes (indicated in **red**) to secure the cable connection.

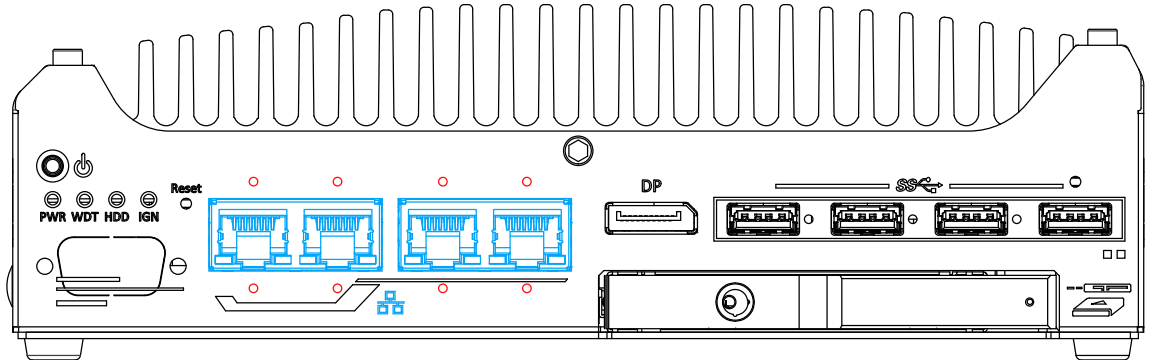

1. To install and make use to the panel screw fix connection, you must acquire panel screw fix cables such as the cable shown below.



2. Simply insert the RJ45 connector into the RJ45 port and secure the top and bottom screws using your fingers or a screw driver.



3.7 FAN Kit Installation (Nuvo-9531 only)



NOTE

Not applicable to “FLATTOP HEATSINK” models!

The fan kit is applicable when you install a 65W CPU into the system. Please refer to the following procedure on how to install the fan kit onto the system.

1. Place the fan on top of the system’s heatsink and secure it with the hex-bolt screws indicated in blue and beware of the orientation of the fan as the fan’s power cable must be within reach of 4-pin fan power connector.



NOTE

With front panel (the panel with DisplayPort/ Ethernet/ USB, etc.) facing you, the fan’s power connector should be on the right, just around the corner from USB ports.

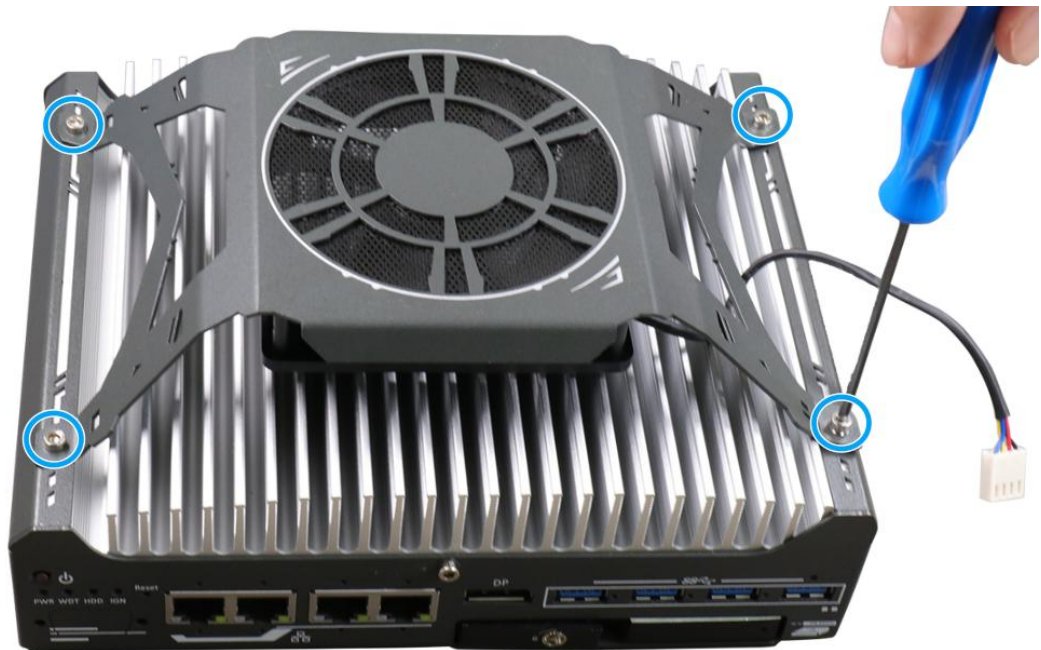

2. With the fan secure, around the corner of USB ports, locate the fan power connector's cover plate, use a small Phillips screwdriver, gently insert it into the gap and bend it outwards to remove it. Connect the 4-pin fan's power cable to the 4-pin fan power connector.



Locate 4-pin power plug location

Insert the 4-pin plug properly

3. Once the power cable is connected, place the supplied cable cover (in the accessory box) over the cable and secure it with the screws indicated to complete the installation.

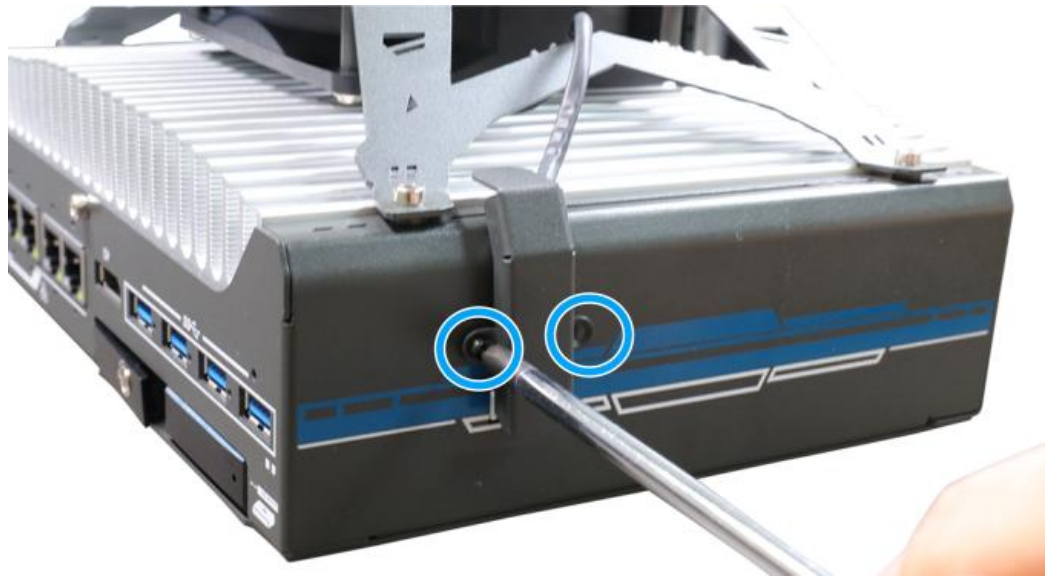

Here's an exploded view of the fan kit.

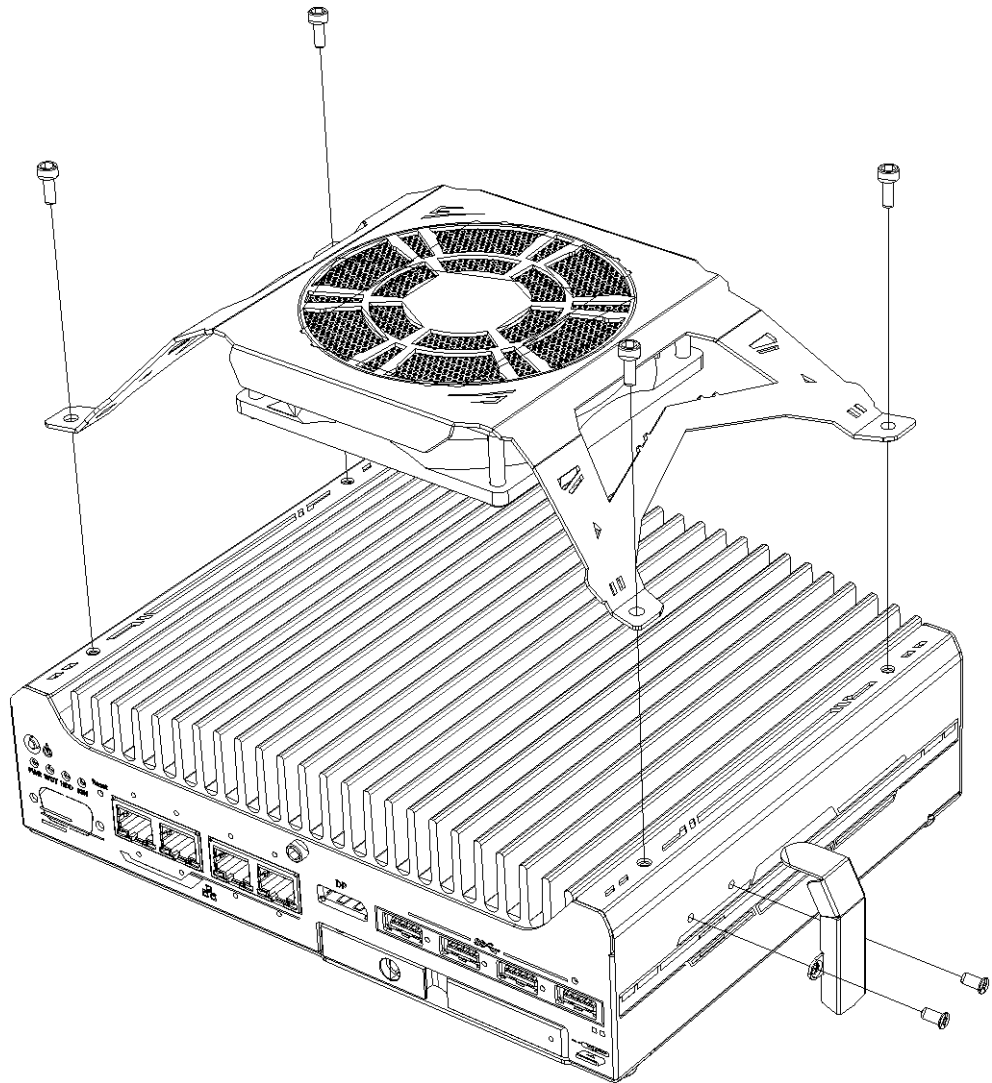

3.8 Mounting Nuvo-9531 Series

Neosys provides versatile mounting methods for Nuvo-9531 series systems. You can use wall-mounting brackets to mount it on the wall. Neosys also offers optional DIN-rail mounting kit to mount it on a DIN-rail. To mount your Nuvo-9531 computer, please refer to the instructions listed below.

3.8.1 Wall-mounting Nuvo-9531 Series

Nuvo-9531 systems have built-in wall-mounting brackets as the standard mounting option. Please follow steps below to mount your Nuvo-9531 computer on a flat surface.

1. Take out the two wall mount brackets from the accessory box and four M4 screws to secure the brackets onto the enclosure.

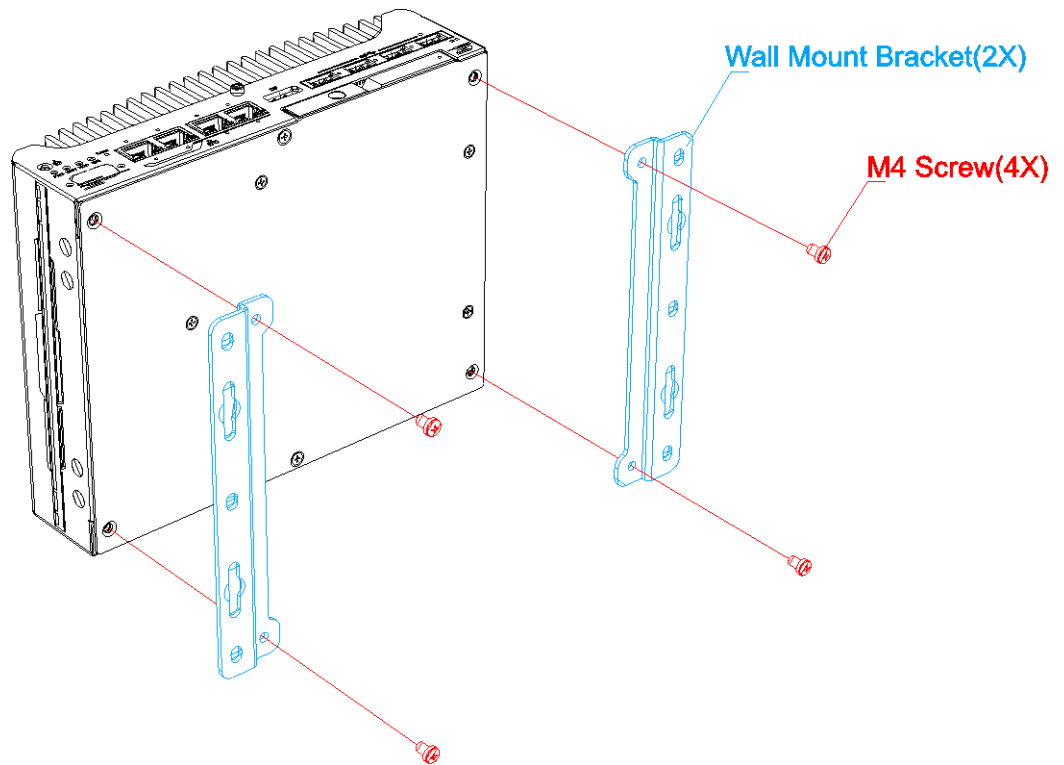

2. Find a sturdy flat surface and secure the system.

3.8.2 Installing DIN-Rail Mounting Kit (Optional)

The kit includes a bracket (in blue) and a DIN-rail mounting clip (in red). You should fix the clip to the bracket using four M4 flat-head screws first (in green), and then fix the bracket assembly to the Nuvo-9531 computer with another four M4 screws. This option can be useful if you want to deploy it inside an equipment cabinet where DIN-rail is available.

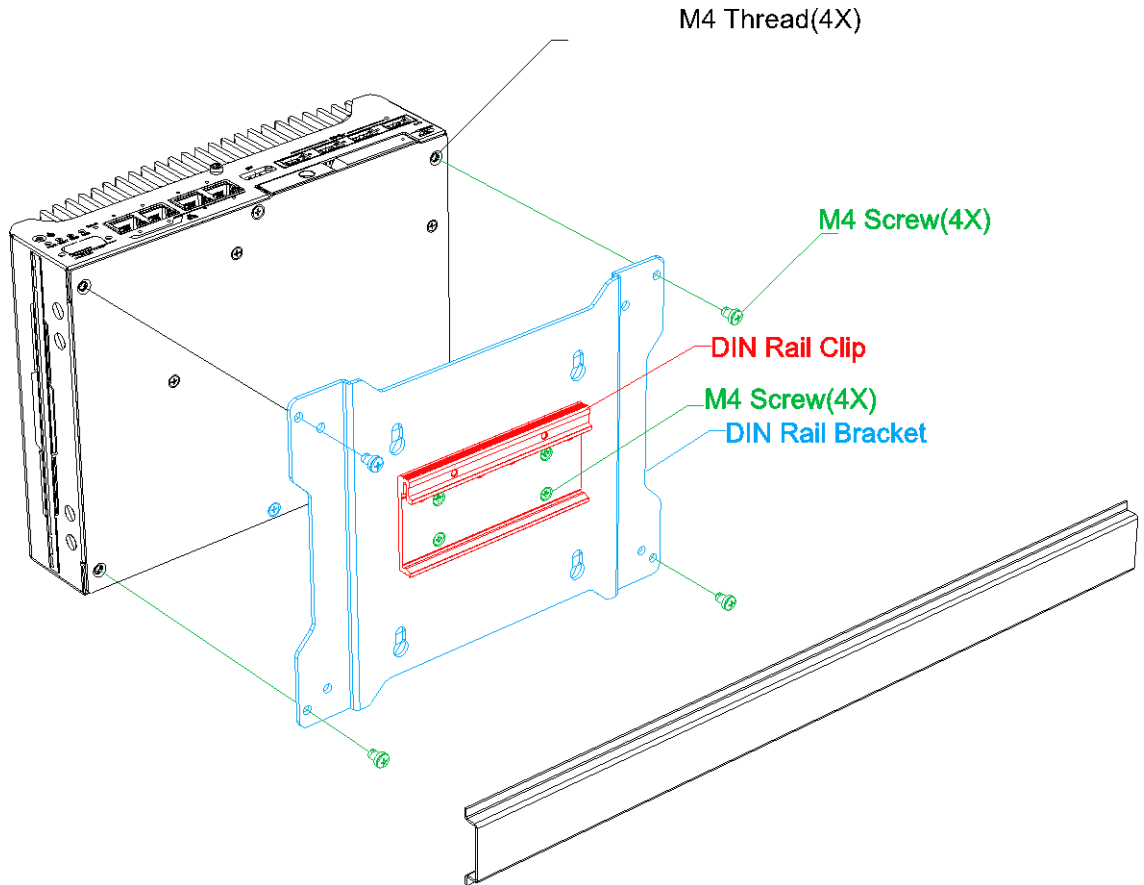

3.9 Installing Nuvo-9531-FT Series

 **WARNING**
 Please **DO NOT** remove the clear film on the thermal pad!

The Nuvo-9531-FT series system rely on thermal conduction through its flattop heatsink with a metallic surface. Designed to be installed within water/ weather proof enclosures, the system can be installed by utilizing the four M4x0.7 screw holes on the flattop heatsink onto the panel of an enclosure.

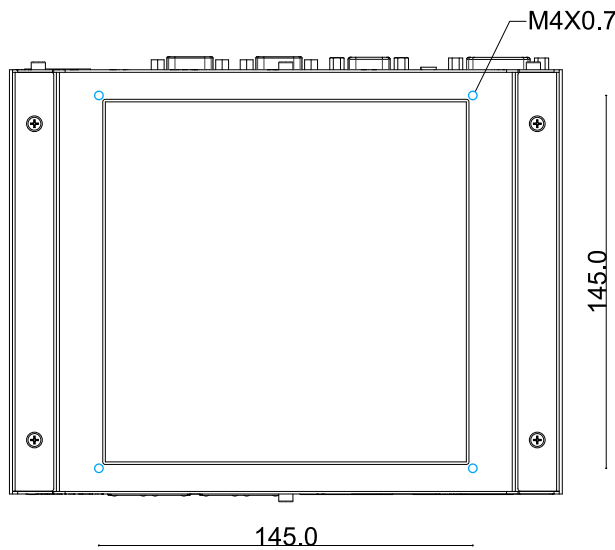

Flattop screw locations



Attached on metal panel in an enclosure

Below are reference temperatures when the system is mounted on steel/ aluminum plate to simulate cabinet environment in high temperature tests.

Test condition (with 35W CPU)	Ambient Operating temperature	CPU temperature	Airflow
Nuvo-9531-FT only	25°C	97°C	-
Mounted on steel plate (60x60x0.2cm)	25°C	63°C	0.5 m/s
Mounted on Aluminum plate (60x60x0.3cm)	25°C	54°C	0.5 m/s
Mounted on steel plate (60x60x0.2cm)	60°C	96°C	0.5 m/s
Mounted on Aluminum plate (60x60x0.3cm)	65°C	93°C	0.5 m/s

3.10 Wall-mounting Nuvo-9531-FT Series (Optional)

 **WARNING**
 Please **DO NOT** remove the clear film on the thermal pad!

To install the optional wall-mount brackets for Nuvo-9531-FT, please refer to the following instructions.

1. With the Ethernet port panel facing you, the wall-mount brackets are secured using screws (indicated in **blue**) on the left and right side of the system enclosure.

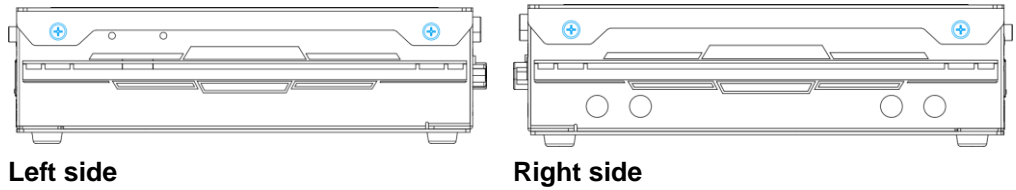

2. The installed wall-mount bracket is as follows and will have the following dimensions.

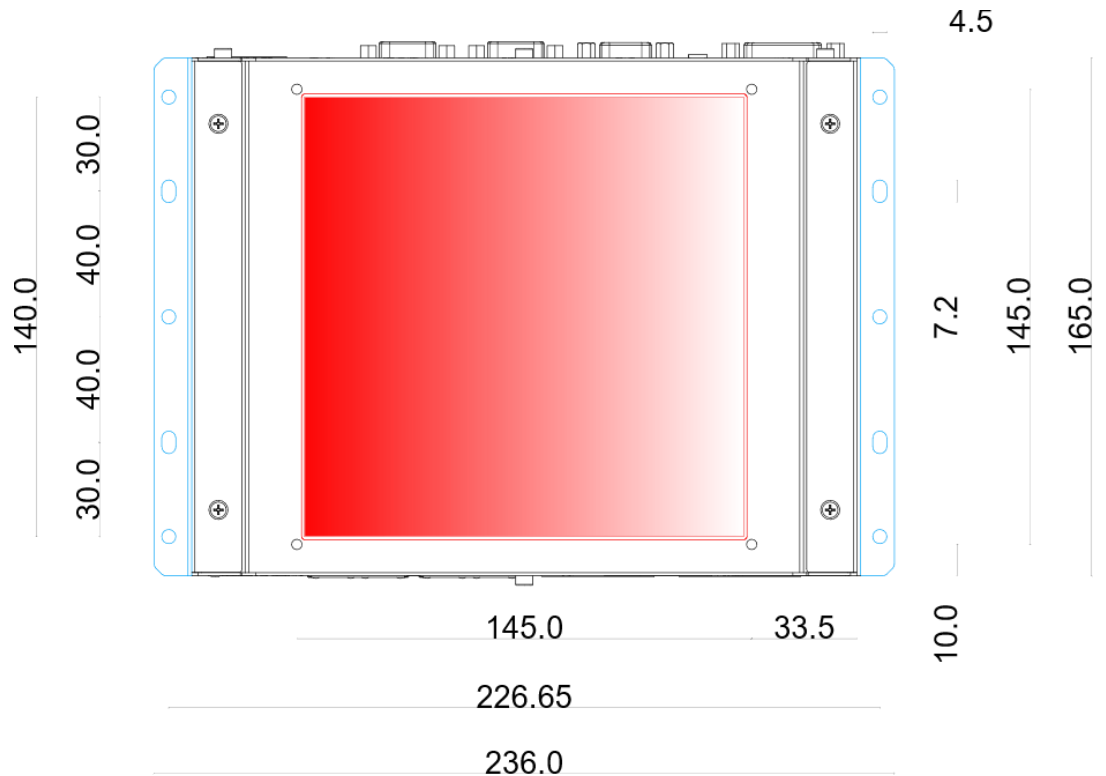

3. When securing with wall-mount brackets, please make sure the flattop heatsink area shaded in red is in contact with a metallic surface as the system’s heatsink rely on conduction for thermal dissipation.

3.11 Powering On the System

There are various methods to power on the system

- Pressing the power button
- Using an external non-latched switch by connecting to the remote on/ off plug
- Sending a LAN packet via Ethernet (Wake-on-LAN)
- System always on
- Powering on via ignition control (for Nuvo-9531-IGN only, please refer to [Ignition Control](#) section)

3.11.1 Powering On Using the Power Button

This is the simplest way to turn on your system. The power button is a non-latched switch and behaves as the ATX-mode on/off control. With DC power connected, pushing the power button will turn on the system and the PWR LED indicator will light up. Pushing the button when system is on will turn off the system. If your operating system supports ATX power mode (i.e. Microsoft Windows or Linux), pushing the power button while the system is in operation will result in a pre-defined system behavior, such as shutdown or hibernation.

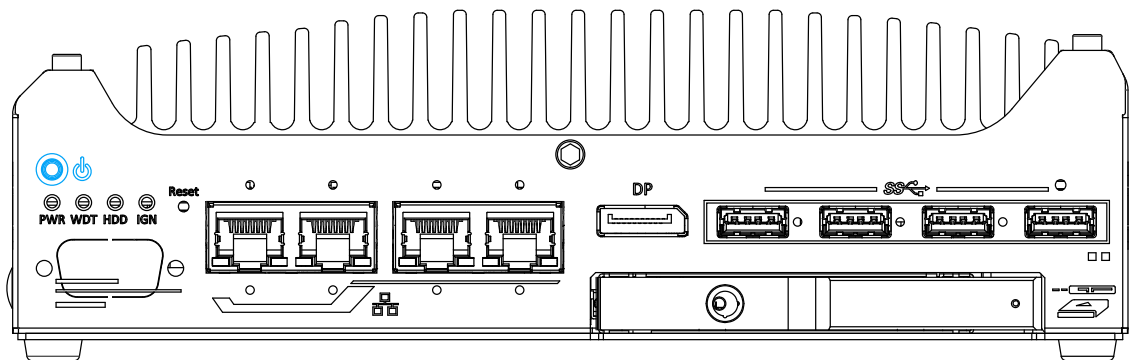

3.11.2 Powering On Using External Non-latched Switch (Remote On/ Off)



NOTE

For Nuvo-9531-IGN systems, the Remote on/off control is not applicable as the on/off function can be triggered from the ignition control.

If your application demands the system to be placed inside a cabinet, you may use an external non-latched switch to power on/ off the system. The system's 3-pin power connector offers "Remote On/ Off" functionality by connecting a non-latched switch, and acts as the ATX-mode power on/off control switch. The external non-latched switch acts exactly the same as the power button on the front panel. To setup and power on/ off the system using an external non-latched switch (ATX-mode), please follow the steps described below.

1. Acquire a non-latched switch and connect it to the **IGN/Remote on/off** and **V+** pins on the 3-pin power connector.
2. Press the power button on the non-latched switch to short the **IGN/Remote on/off** and **V+** pins. Hold for at least one second and release the button.

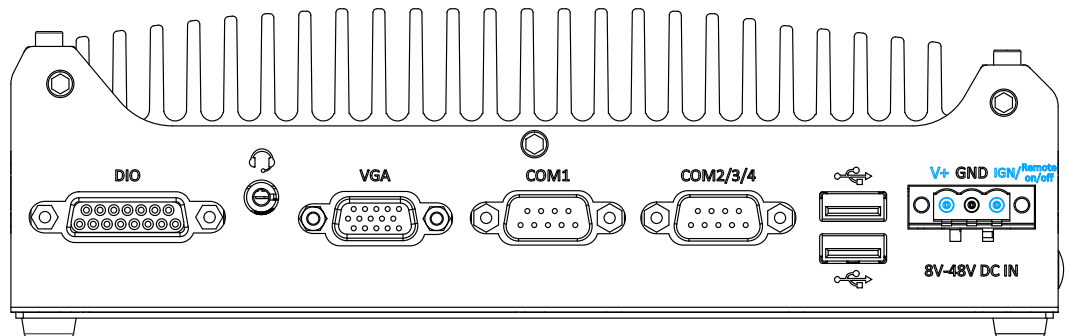

3. When the system is powered on, you may press and hold the power button (for at least one second) on the non-latched switch to turn off the system, or to execute a pre-defined action.

3.11.3 Powering On Using Wake-on-LAN

Wake-on-LAN (WOL) is a mechanism to wake up a computer system from a S5 (system off with standby power) state via issuing a magic packet. The system's Wake-on-LAN compatible GbE port is shown below.

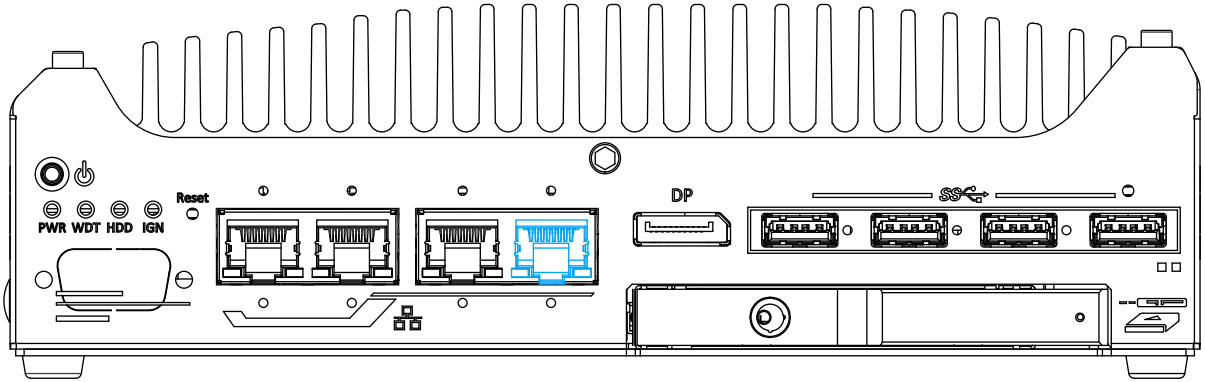

 **NOTE**

Please make sure the Intel chipset and Ethernet driver has been properly installed prior to setting up WOL function.

To enable WOL function, please set up WOL settings in the BIOS and in the operating system by follow the steps described below.

1. When the system boots up, press F2 to enter BIOS setup utility.
2. Go to the **[Power]>[Wake On LAN]** and set it to **[Enabled]**.
3. Press F10 to **“Save changes and exit BIOS”** and allow the system boot into the operating system.
4. Once booted into the Windows system, press **“Windows key + E”**, right-click on **“Network>Properties>Change adapter settings”**. Locate and double-click on the adapter

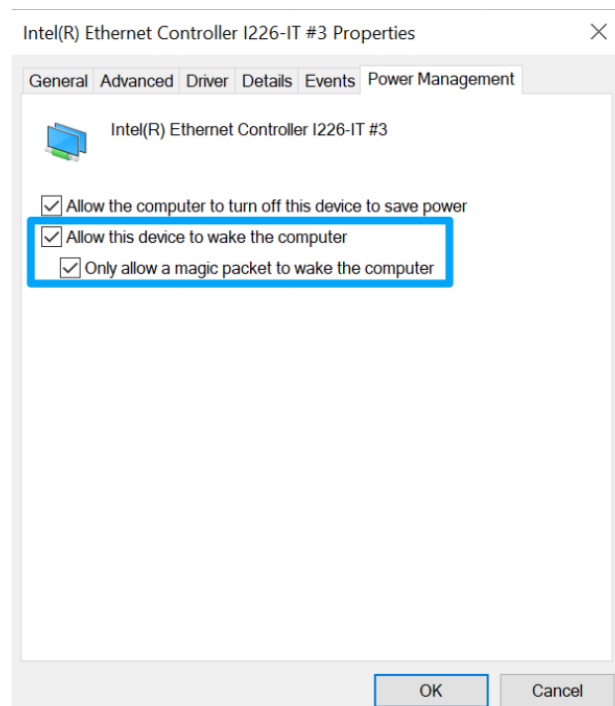

Intel® I226 Gigabit Network Connection, click on **Configure**.

- Click on the **Power Management** tab and check the following options. Click on OK when done.

Magic Packet

The magic packet is a broadcast frame containing anywhere within its payload 6 bytes of all 255 (FF FF FF FF FF FF in hexadecimal), followed by sixteen repetitions of the target computer's 48-bit MAC address.

For example, NIC's 48-bit MAC Address is 78h D0h 04h 0Ah 0Bh 0Ch

DESTINATION	SOURCE	MISC
FF FF FF FF FF FF		
78 D0 04 0A 0B 0C	78 D0 04 0A	
0B 0C		
78 D0 04 0A 0B 0C	78 D0 04 0A	
0B 0C		
78 D0 04 0A 0B 0C	78 D0 04 0A	
0B 0C		
78 D0 04 0A 0B 0C	78 D0 04 0A 0B 0C	
78 D0 04 0A 0B 0C	78 D0 04 0A 0B 0C	
78 D0 04 0A 0B 0C	78 D0 04 0A 0B 0C	
78 D0 04 0A 0B 0C	78 D0 04 0A 0B 0C	
78 D0 04 0A 0B 0C	78 D0 04 0A 0B 0C	
MISC		CRC

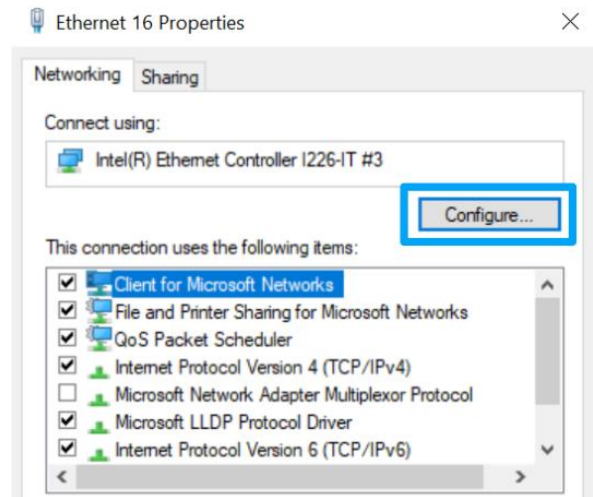

There are some free tools available on Internet that can be used to send a magic packet. Please refer to the following link to understand more about [Magic Packet](#).

3.11.4 System Always On

The system has an “Always On” feature to ensure when deployed in hard to access locations, such as in a cabinet, roadside, etc., should the system power off due to an unforeseen reason, it will detect the power off status and automatically trigger the power on mechanism to ensure the system is always operational.

To enable to the system Always On function, please refer to the following instruction:

1. Locate the 3-pin terminal connector on the system.

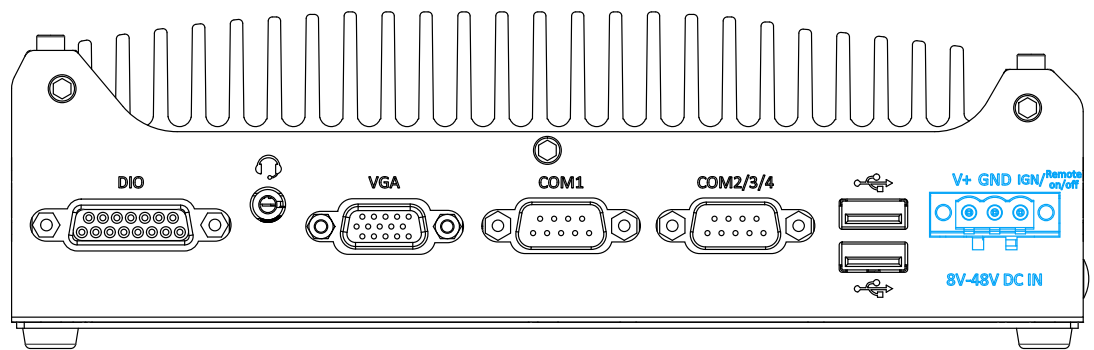

2. Simply short the V+ pin and the IGN/ Remote on/off pin, and power-on the system to activate the Always On function.

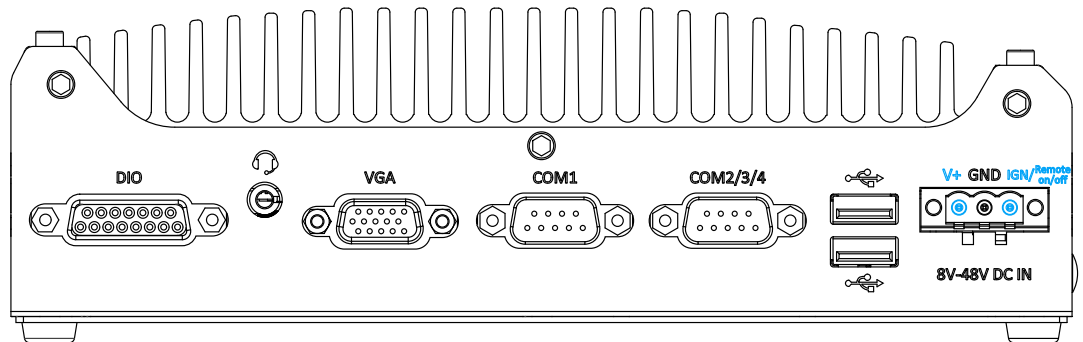

3. Once the pins are shorted, when the system is in shutdown state (S5), the system will detect this status and automatically reboot in 5 seconds.

3.12 Ignition Power Control (Optional)

The ignition power control module for in-vehicle applications is a MCU-based implementation that monitors the ignition signal and reacts to turn on/off the system according to predefined on/off delay. Its built-in algorithm supports other features such as ultra-low power standby, battery-low protection, system hard-off, etc. In this section, we'll illustrate the principle of ignition power control and operation modes.

3.12.1 Principles of Ignition Power Control

The basic concept of ignition power control module is to control the timing correlation between ignition signal and system power status. A typical timing correlation is described in following diagram.

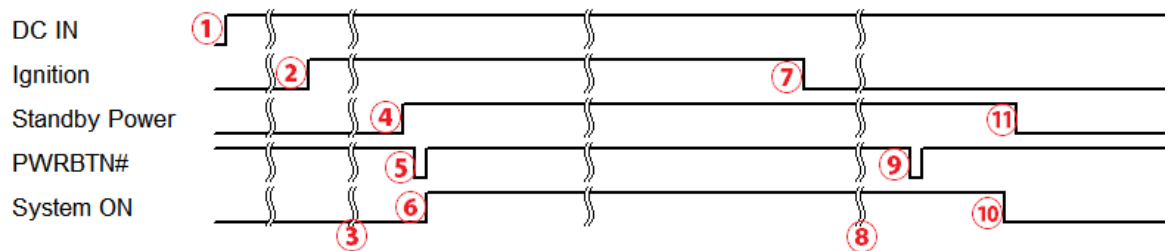

1. When DC power is supplied to the system, MCU starts to periodically detect ignition signal. Note that only MCU is working at this moment and the overall power consumption is less than 2 mW.
2. Ignition signal is active (both 12VDC and 24VDC ignition signals are accepted).
3. MCU starts to count a pre-defined power-on delay.
4. Once power-on delay expired, MCU turns on necessary standby power for the system (3.3VSB & 5VSB).
5. A PWRBTN# pulse is then issued to turn on the system (equivalent to one pressing the power button on the front panel).
6. The system is booting and becomes operational.
7. After a period of time, the ignition signal becomes inactive.
8. MCU starts to count a pre-defined power-off delay.
9. Once power-off delay expired, another PWRBTN# pulse is issued to perform a soft-off for the system (ex. a normal shutdown process for Windows system).
10. The system is completely shut down.
11. As MCU detects system is off, it turns off the standby power for the system, and operates in low power mode again (< 2mW power consumption).

3.12.2 Additional Features of Ignition Power Control

In addition to the typical timing correlation, the ignition power control module offers additional features to provide additional reliability for in-vehicle applications.

1. Low battery detection

The ignition power control module continuously monitors the voltage of DC input when the system is operational. If input voltage is less than 9V (for 12VDC input) or less than 18V (for 24VDC input) over a 60-second duration, it will shut down the system automatically.

2. Guarded power-on/ power-off delay duration

If ignition signal goes inactive during the power-on delay duration, the ignition power control module will cancel the power-on delay process and go back to idle status. Likewise if ignition signal goes active during the power-off delay duration, the ignition power control module will cancel the power-off delay process and keep the system running.

3. System hard-off

In some cases, system may fail to shutdown via a soft-off operation due to system/ application halts. The ignition power control module offers a mechanism called “hard-off” to handle this unexpected condition. By detecting the system status, it can determine whether the system is shutting down normally. If not, the ignition power control module will force cut-off the system power 10 minutes after the power-off delay duration.

4. Smart off-delay

The ignition power control module offers two modes (mode 13 & mode 14) which have very long power-off delay duration for applications require additional off-line time to process after the vehicle has stopped. In these two modes, the ignition power control module will automatically detect the system status during the power-off delay duration. If the system has shutdown (by the application software) prior to power-off delay expiring, it will cut off the system power immediately to prevent further battery consumption.

3.12.3 Wiring Ignition Signal

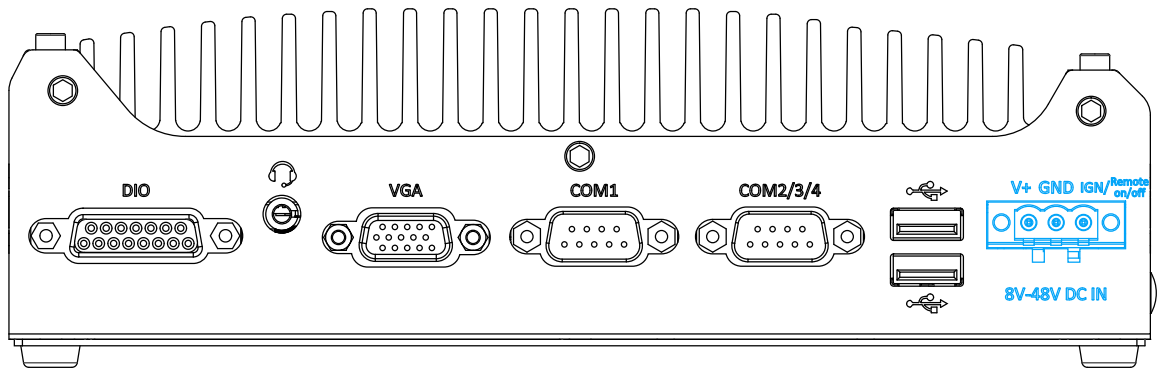

To have ignition power control for in-vehicle usage, you need to supply IGN signal to the system. The IGN input is located on the 3-pin pluggable terminal block (shared with DC power input). Below is the typical wiring configuration for in-vehicle applications.

1. Connect car Battery+ line (12V for sedan, 24V for bus/truck) to V+.
2. Connect car Battery-/ GND line to GND.
3. Connect ACC line to IGN.



WARNING

Please make sure your DC power source and IGN signal share the same ground.

IGN input accepts 8-48VDC. Supply a voltage higher than 48VDC may damage the system.

3.12.4 Configure your Windows system

When applying ignition power control to your system, please make sure you've configured your Windows system to initiate a shutdown process when pressing the power button. By default, Windows 10 goes to sleep (S3) mode when power button is pressed. As sleep (S3) is not a complete shutdown behavior, the ignition control function does not recognize the finish of a normal shut down process and thus users will encounter a system hard-off (power cut-off after 10 minutes). Please configure "When I press the power button" to "Shut down" in your Windows system settings.

Power button settings

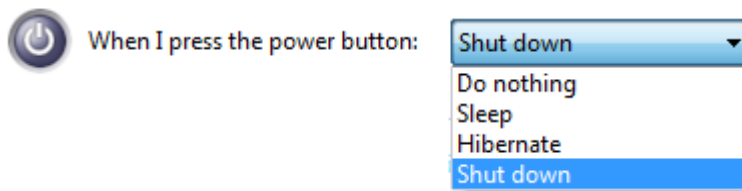

3.12.5 Operation Modes of Ignition Power Control

You can use the rotary switch to configure the operation mode. The system offers 16 (0~15) operation modes with different power-on/power-off delay configurations.

The ignition control rotary switch can be located on the motherboard. Please refer to the “Disassembling the enclosure” section on how to remove the bottom panel and gaining access to the rotary switch.

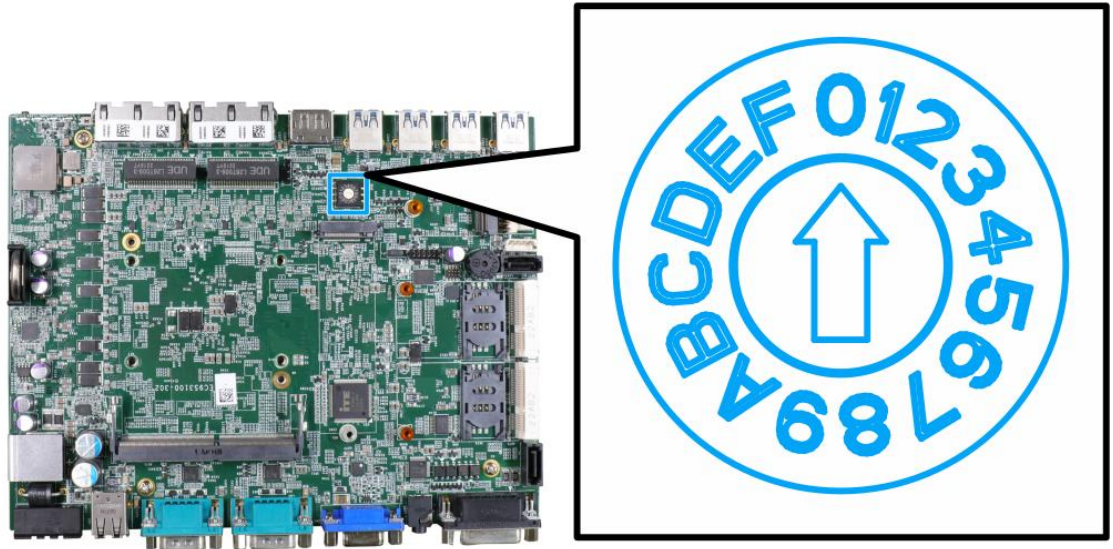

- **Mode 0**

Mode 0 is the ATX mode without power-on and power-off delay. User can only use the power button on the front panel to turn on or turn off the system.

Mode	Power-on Delay	Power-off Delay	Hard-off Timeout
0	N/A	N/A	N/A

- **Mode 1**

Mode 1 is AT mode without power-on and power-off delay. The system automatically turns on when DC power is applied. A retry mechanism is designed to repeat the power-on cycle if the system fails to boot up.

Mode	Power-on Delay	Power-off Delay	Hard-off Timeout
1	N/A	N/A	N/A

- **Mode 2**

Mode 2 is designed to have a very minor power on/ off delay of 160ms for applications that requires the system to start up almost at the same as the rest of the equipment it is working in collaboration with.

Mode	Power-on Delay	Power-off Delay	Hard-off Timeout
2	160ms	160ms	10 minutes

- **Mode 3 ~ Mode 12**

Mode 3 ~ Mode 12 have various power-on delay and power-off delay. Each mode supports a hard-off timeout of 10 minutes.

Mode	Power-on Delay	Power-off Delay	Hard-off Timeout
3	10 seconds	10 seconds	10 minutes
4	10 seconds	1 minute	10 minutes
5	10 seconds	5 minutes	10 minutes
6	30 seconds	1 minute	10 minutes
7	30 seconds	5 minutes	10 minutes
8	30 seconds	10 minutes	10 minutes
9	3 minutes	1 minute	10 minutes
10 (A)	3 minutes	10 minutes	10 minutes
11 (B)	3 minutes	30 minutes	10 minutes
12 (C)	10 minutes	30 minutes	10 minutes

- **Mode 13 (D) / Mode 14 (E)**

Mode 13 and Mode 14 are ignition power control modes with very long power-off delay. Both modes support the feature of “smart off-delay”, which automatically detect system status during power-off delay duration and cut off system power if system is off in prior to power-off delay expired.

Mode	Power-on Delay	Power-off Delay	Hard-off Timeout
13 (D)	30 seconds	2 hours	10 minutes
14 (E)	3 minutes	2 hours	10 minutes

- **Mode 15 (F)**

Reserved

4 System Configuration

4.1 BIOS Settings

The system is shipped with factory-default BIOS settings meticulously programmed for optimum performance and compatibility. In this section, we'll illustrate some of BIOS settings you may need to modify. Please always make sure you understand the effect of change before you proceed with any modification. If you are unsure of the function you are changing, it is recommended to change one setting at a time to see its effect(s).

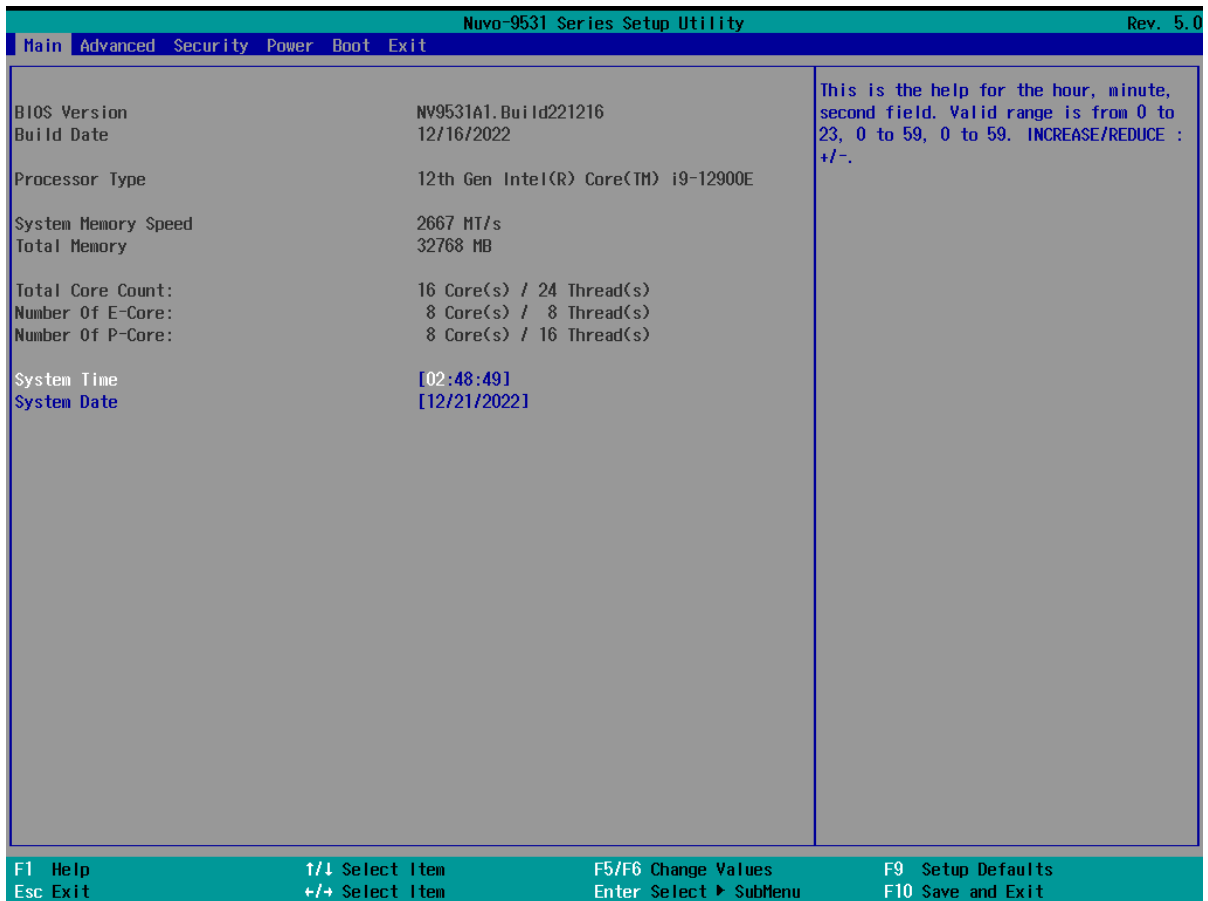

 **NOTE**

Not all BIOS settings will be discussed in this section. If there is a particular BIOS setting you are after but is not discussed in this section, please contact Neousys Technical Support staff.

4.1.1 COM1 Configuration

The system's COM1 port support RS-232 (full-duplex), RS-422 (full-duplex) and RS-485 (half-duplex) mode. You can set the COM1 operating mode via BIOS settings.

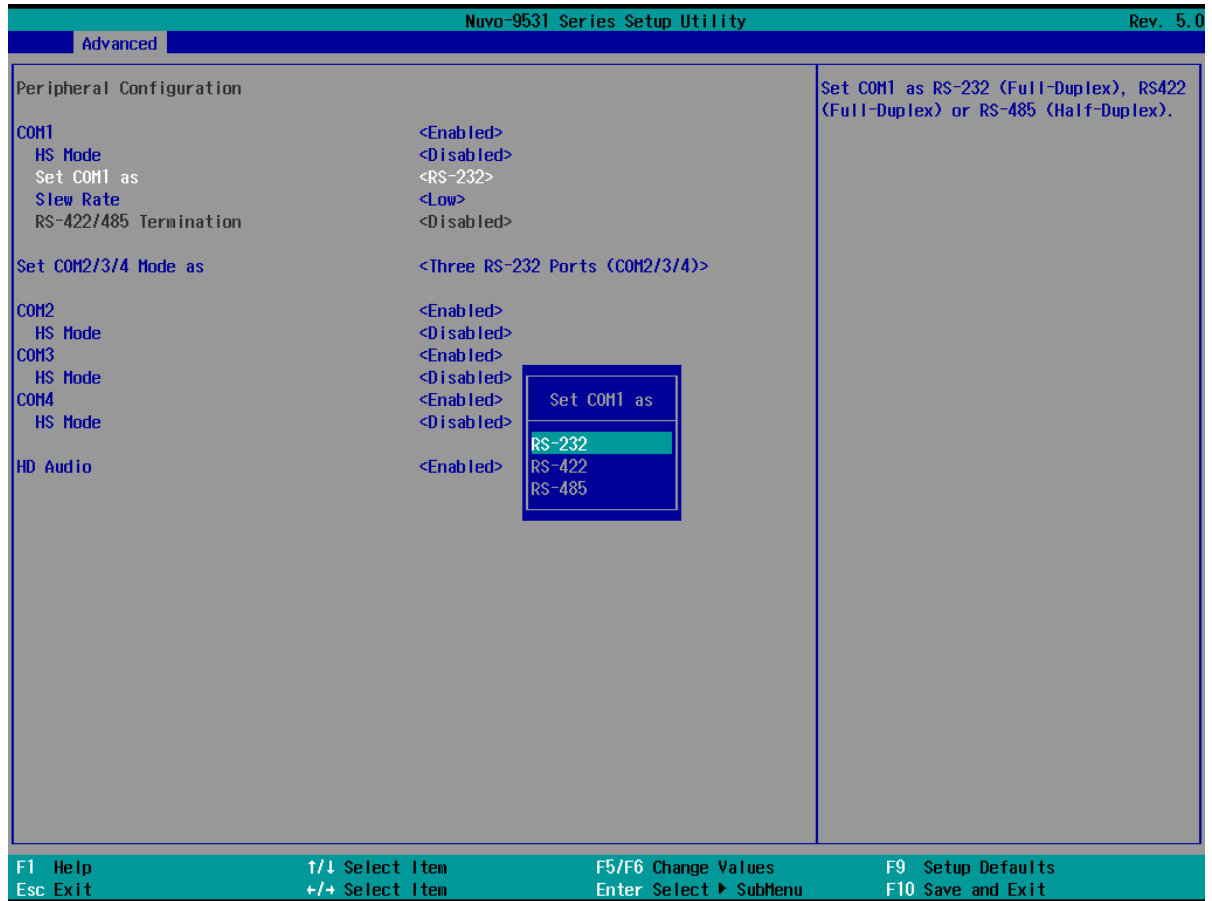

To set COM port operating mode:

1. Press **F2** when the system boots up to enter the BIOS setup utility.
2. Go to **[Advanced] → [Peripheral Configuration]**.
3. Set the **[Set COM1 Mode as]** option to the desired mode.
4. Once set, press **F10** to save setting and exit.

4.1.2 COM Port Slew Rate

Another option in BIOS called “*Slew Rate*” defines how sharp the rising/falling edge is for the output signal of COM1. For long-distance RS-422/ 485 transmission, you may set the “*Slew Rate*” option as “High” to improve signal quality. For RS-422/485 communication, the “*RS-422/ 485 Termination*” option determines whether to enable/disable internal termination of RS-422/ 485 transceiver according to your wiring configuration (e.g. with or without external termination).

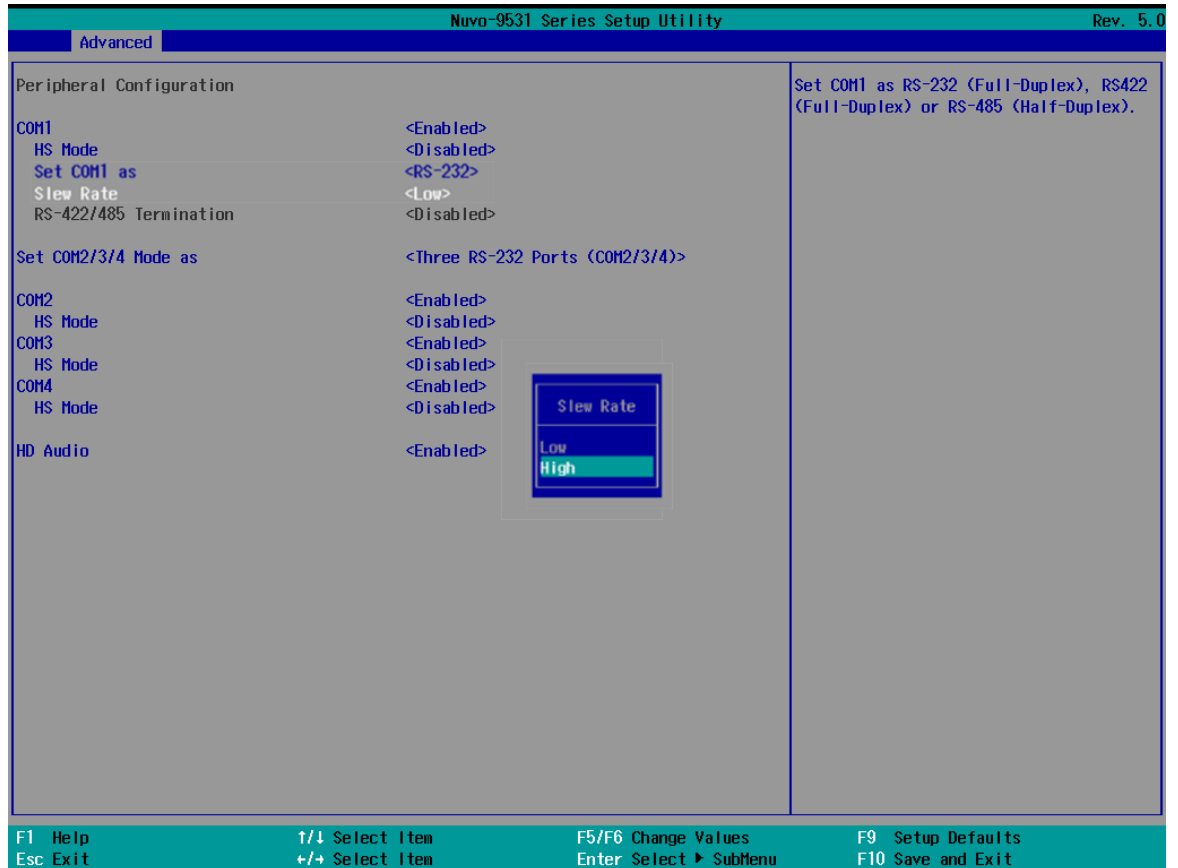

To set COM port Slew rate:

1. Press **F2** when the system boots up to enter the BIOS setup utility.
2. Go to **[Advanced]** → **[Peripheral Configuration]**.
3. Select and highlight the COM port > **[Slew Rate]**.
4. Set it to the desired mode **[Low]** or **[High]** and press Enter.
5. Once set, press **F10** to save setting and exit.

4.1.3 COM Port High Speed Mode

The high speed mode of each COM port effectively allows for the port's baud rate generator to operate at 8x the speed with an effective baud rate of 921,600 bps (115,200 x 8). Please refer to the following instructions on how to enable the high speed mode for your COM port (COM1 used as an example).



To set COM port high speed mode:

1. Press **F2** when the system boots up to enter the BIOS setup utility.
2. Go to **[Advanced] > [Peripheral Configuration]**.
3. Enable or set the **[Set COM1 Mode as]** option to the desired mode.
4. Highlight **[HS Mode]** and press ENTER to bring up options, highlight **[Enable]** and press ENTER.
5. Once set, press **F10** to save setting and exit.

4.1.4 COM2/3/4 Port Configuration

The system's [COM2/ 3/ 4 ports](#) support RS-232 (full-duplex) while COM2 also supports RS-422 (full-duplex) and RS-485 (half-duplex) mode. The operating mode can be configured via the BIOS. Another option in BIOS called “*Slew Rate*” defines how sharp the rising/falling edge is for the output signal. For long-distance RS-422/485 transmission, you may set the “*Slew Rate*” option as “High” to improve signal quality. For RS-422/485 communication, the “*RS-422/485 Termination*” option determines whether to enable/disable internal termination of RS-422/485 transceiver according to your wiring configuration (e.g. with or without external termination).

To set COM2/ 3/ 4 operating mode:

1. Press **F2** when the system boots up to enter the BIOS setup utility.
2. Go to **[Advanced]** → **[Peripheral Configuration]**.
3. Set the **[Set COM2/ 3/ 4 Mode as]** option to the desired mode.
4. Once set, press **F10** to save setting and exit.

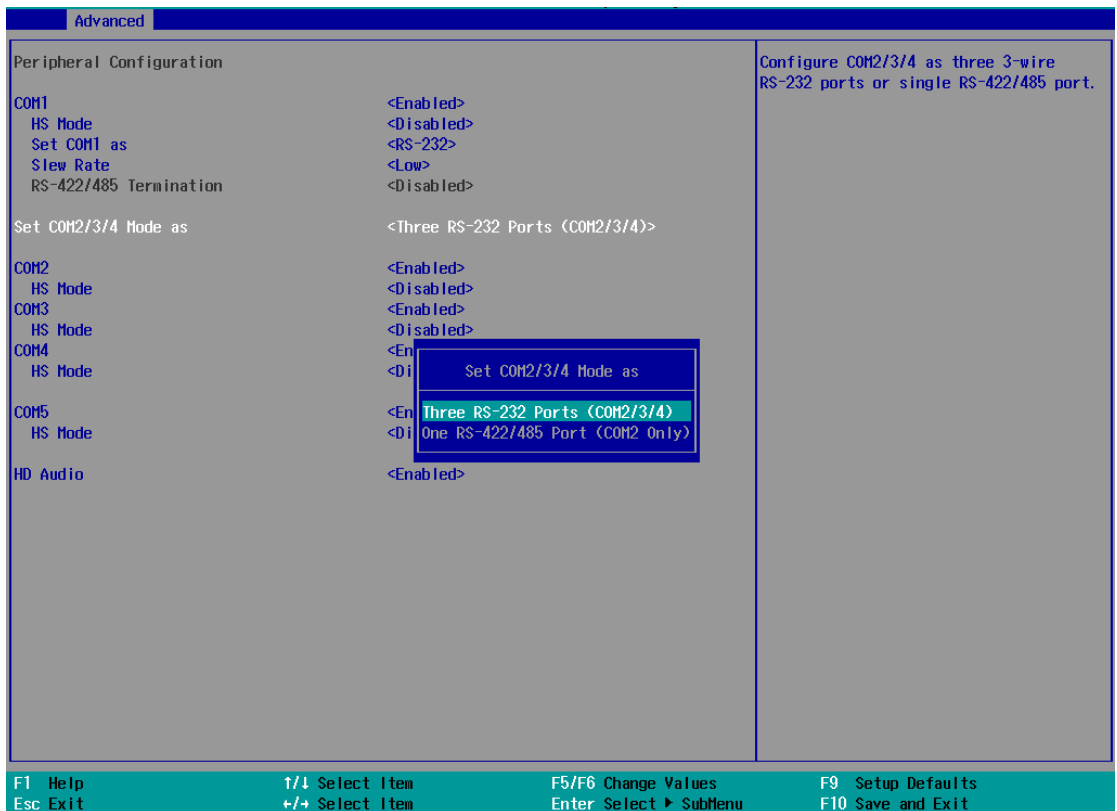

4.1.5 TPM Availability

Trusted Platform Module (TPM) is a hardware-based cryptoprocessor to secure hardware by integrating cryptographic keys into devices. The system is designed with on-board TPM 2.0 module. As TPM 2.0 requires 64-bit Windows 10 with UEFI boot mode, it is enabled in BIOS by default.

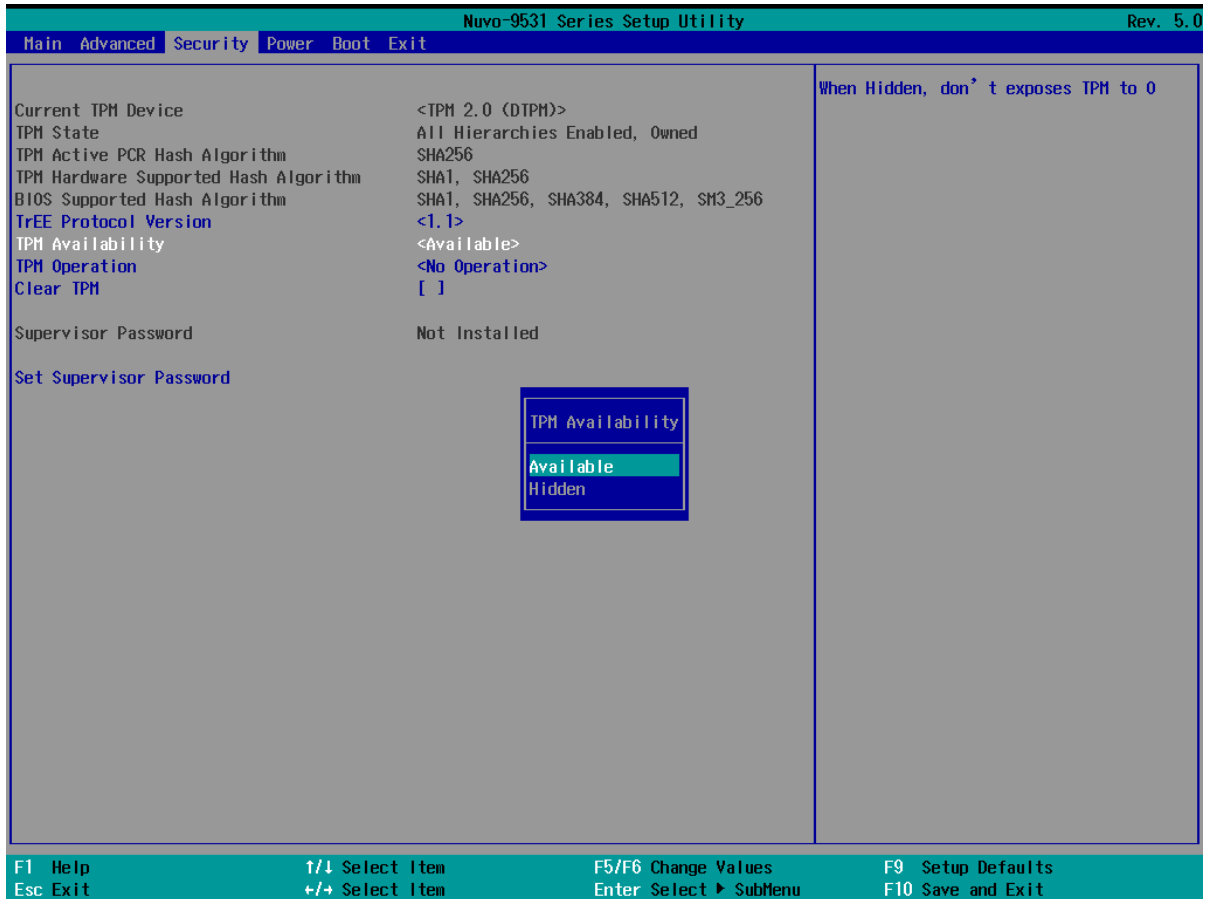

To enable TPM availability:

1. When system boots up, press F2 to enter BIOS setup utility.
2. Go to **[Security] > [TPM Availability]**, press ENTER to bring up Options, Available/Hidden.
3. Highlight your selection, press Enter and press F10 to “Exit Saving Changes”.

4.1.6 Power over Ethernet (PoE) Power Enable (Optional)

Power over Ethernet (PoE) supplies electrical power and data on a standard CAT-5/CAT-6 Ethernet cable. Acting as a PoE PSE (Power Sourcing Equipment), compliant with IEEE 802.3at, each PoE port delivers up to 25W to a Powered Device (PD). The system has a total 100W power budget. The PoE power can be Enabled/ Disabled in the BIOS.

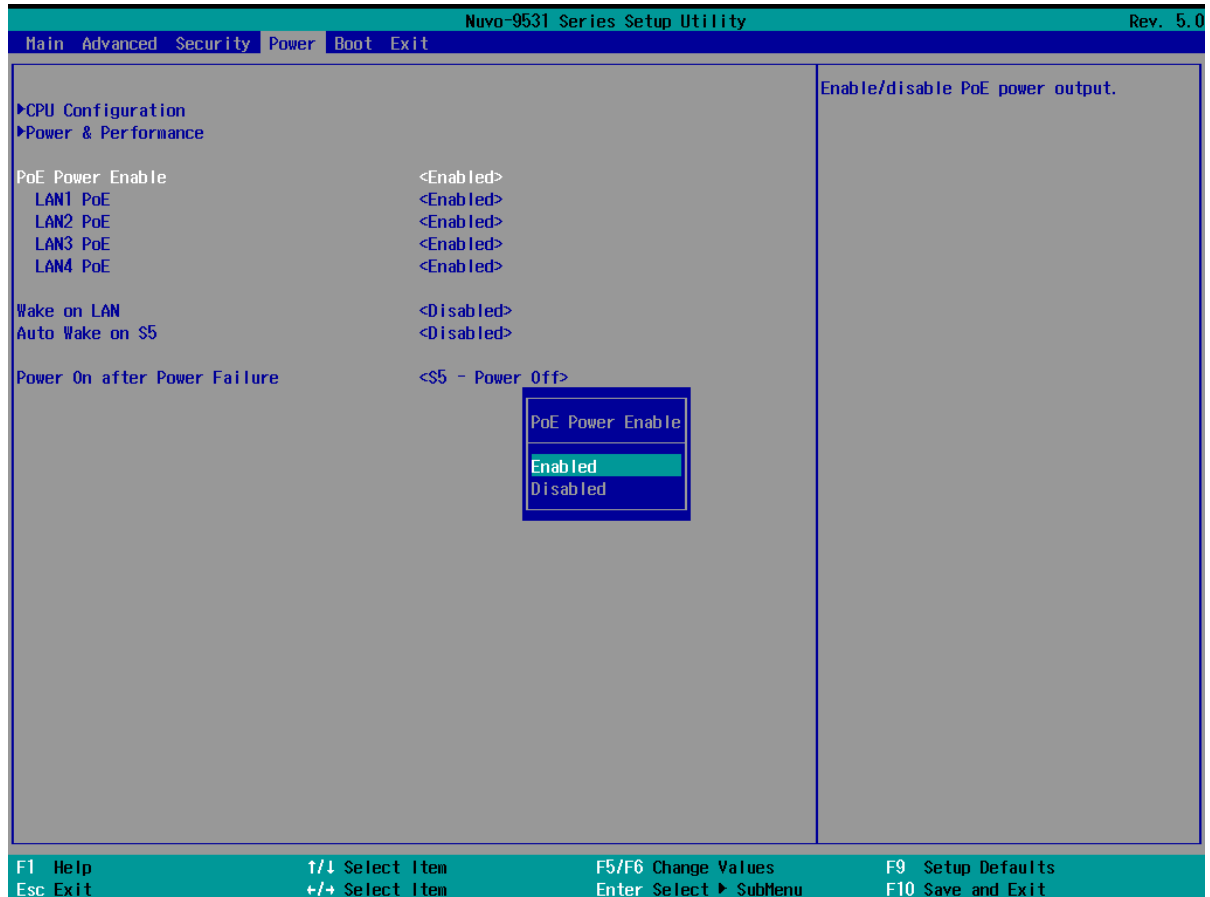

To enable/ disable "PoE Power Enable" option:

1. When system boots up, press F2 to enter BIOS setup utility.
2. Go to **[Power] > [PoE Power Enable]**.
3. Press ENTER to bring up setting options, scroll to the setting (Enabled/ Disabled) you desire and press ENTER to set.

- You can also enable/ disable each port, individually. Simply use the arrow key to highlight the port, press ENTER to bring up options (Enable/ Disable), press ENTER again to select the option.

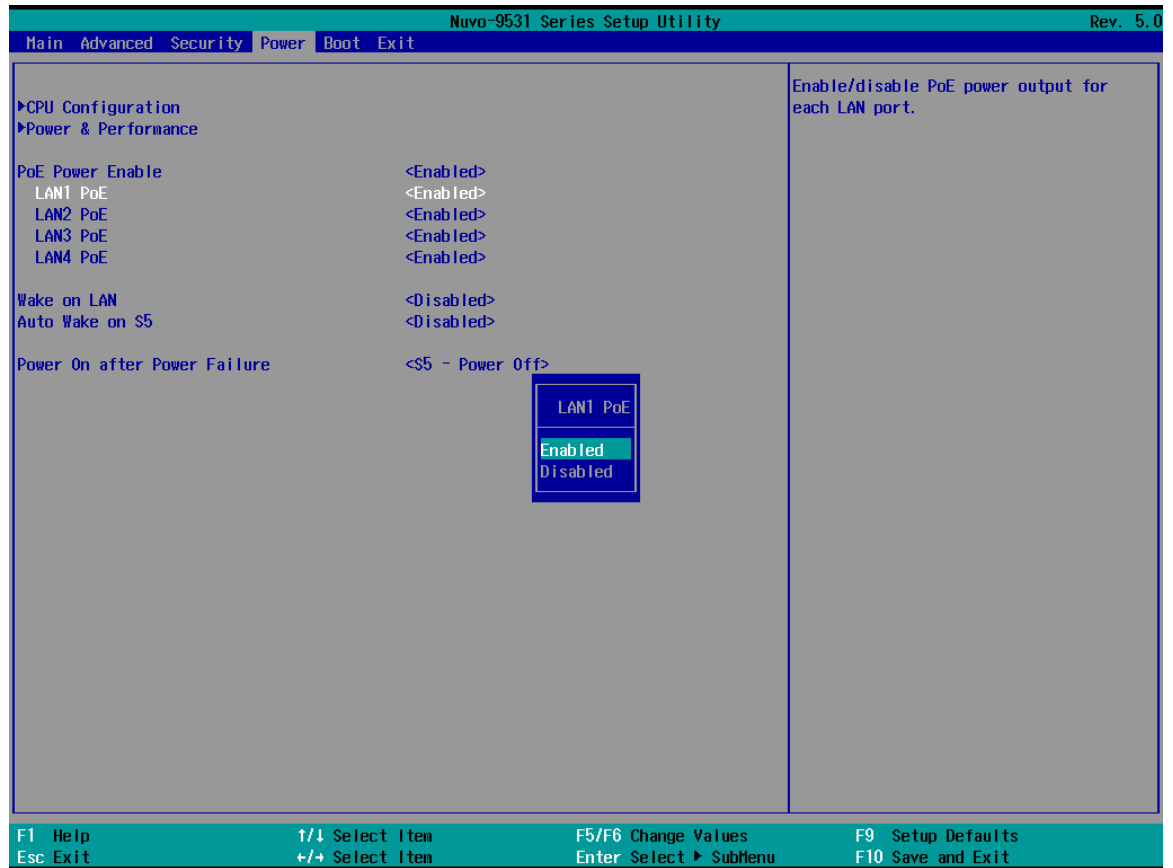
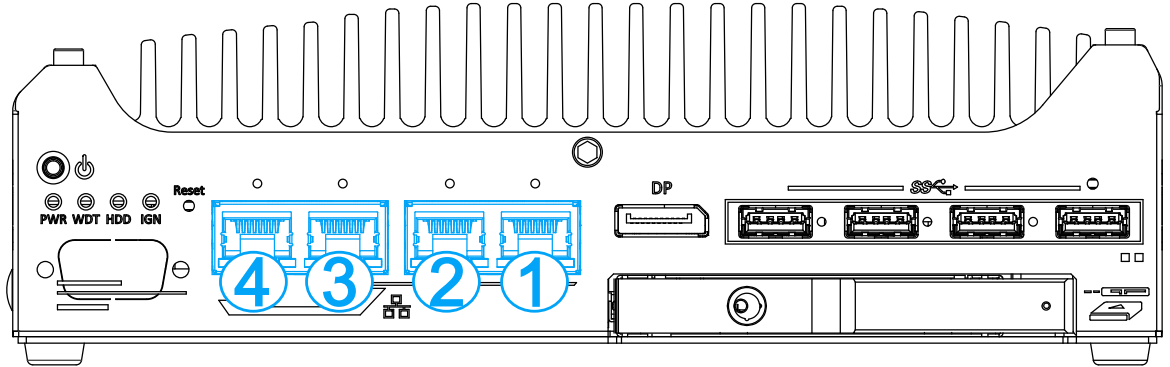

- Press F10 to “Exit Saving Changes”.

4.1.7 Power On After Power Failure Option

This option defines the behavior of system when DC power is supplied.

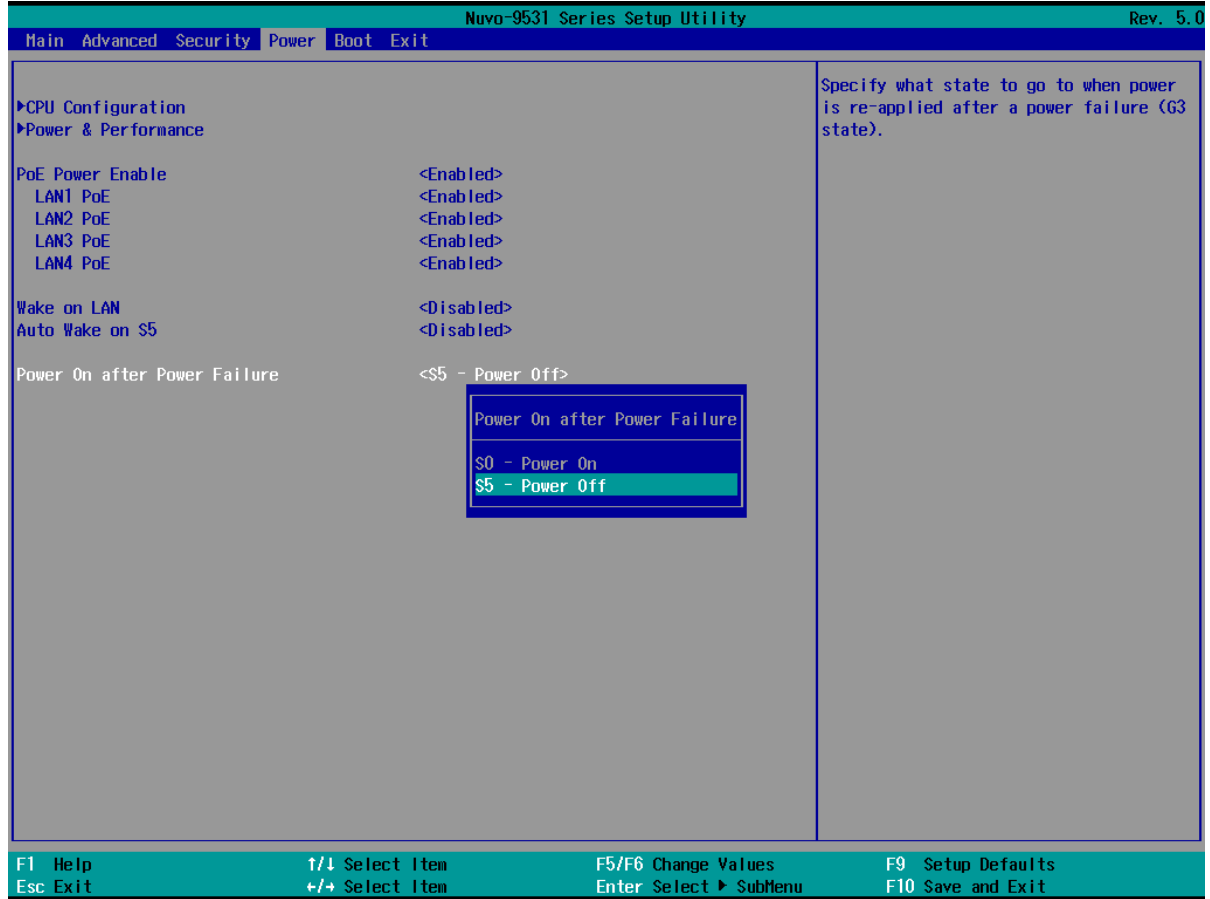

Value	Description
S0 – Power On	System is powered on when DC power is supplied.
S5 – Power Off	System is kept in off state when DC power is supplied.

To set “Power On after Power Failure” option:

1. When system boots up, press F2 to enter BIOS setup utility.
2. Go to **[Power] > [Power On after Power Failure]**.
3. Scroll down to highlight **[Power On after Power Failure]**, press Enter to bring up setting options, S0 – Power On or S5 – Power Off, and press Enter to select the setting.
4. Press F10 to “Exit Saving Changes”.

4.1.8 Power & Performance (CPU SKU Power Configuration)

The system supports various Intel 14th/ 13th/ 12th-Gen CPUs. A unique feature, “**SKU Power Config**” is implemented in BIOS to allow users to specify user-defined SKU power limit. Although the system is designed to have best thermal performance with CPUs of 35W TDP, you can install a 65W CPU with the fan kit installed. Alternatively, you can install a 65W CPU and limit its SKU power (to 35W) to obtain more computing power. This feature gives you the flexibility of CPU selection and great balance between computing power and operating temperature range.

To configure the CPU SKU power limit:

1. When the system boots up, press F2 to enter BIOS setup utility.
2. Go to **[Power]** → **[Power & Performance]**.

Select a proper value of SKU power limit for **[SKU Power Config]** option.

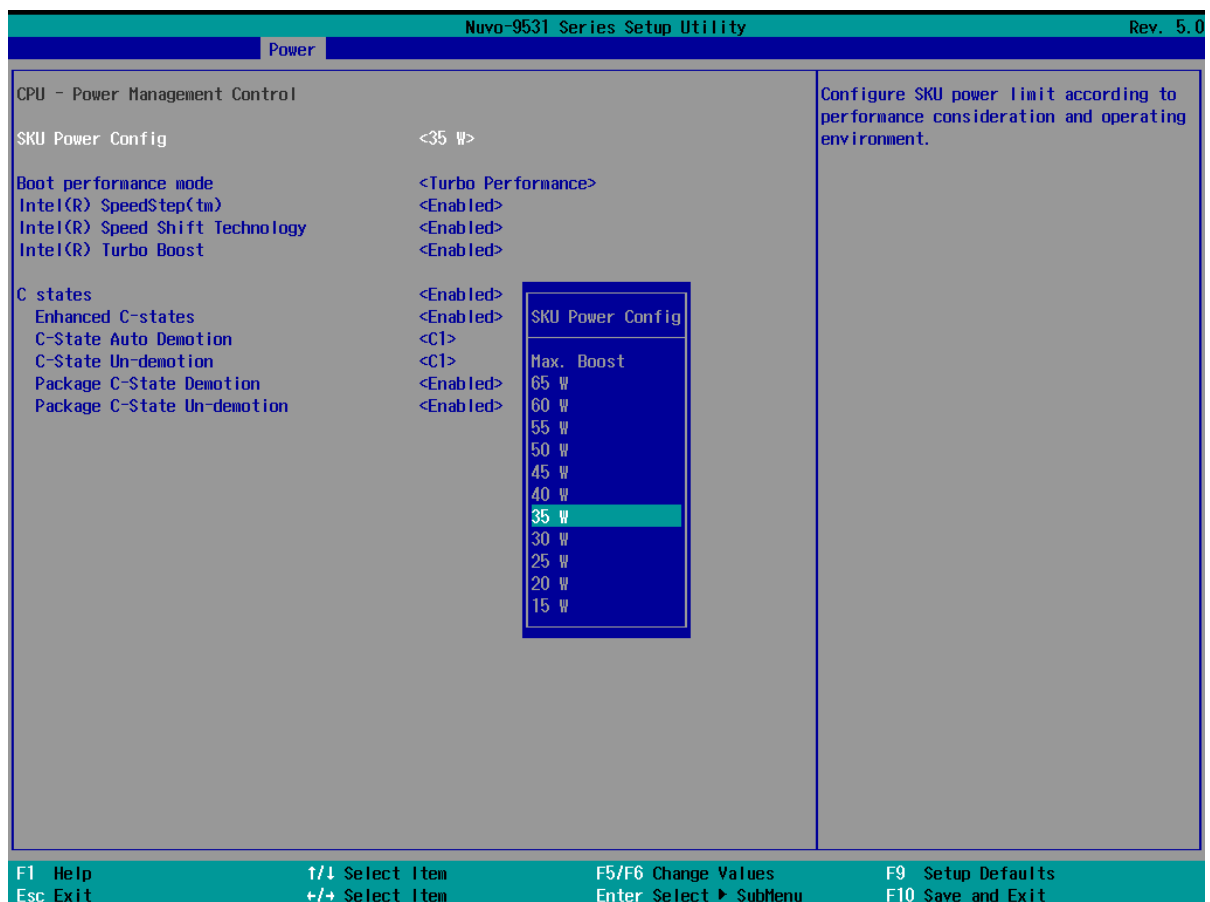

4.1.10 Boot Menu

The Boot menu in BIOS allows you to specify the system’s boot characteristics by setting bootable device components (boot media) and method. Or, you may press F12 upon system start up and select a device you wish boot from.

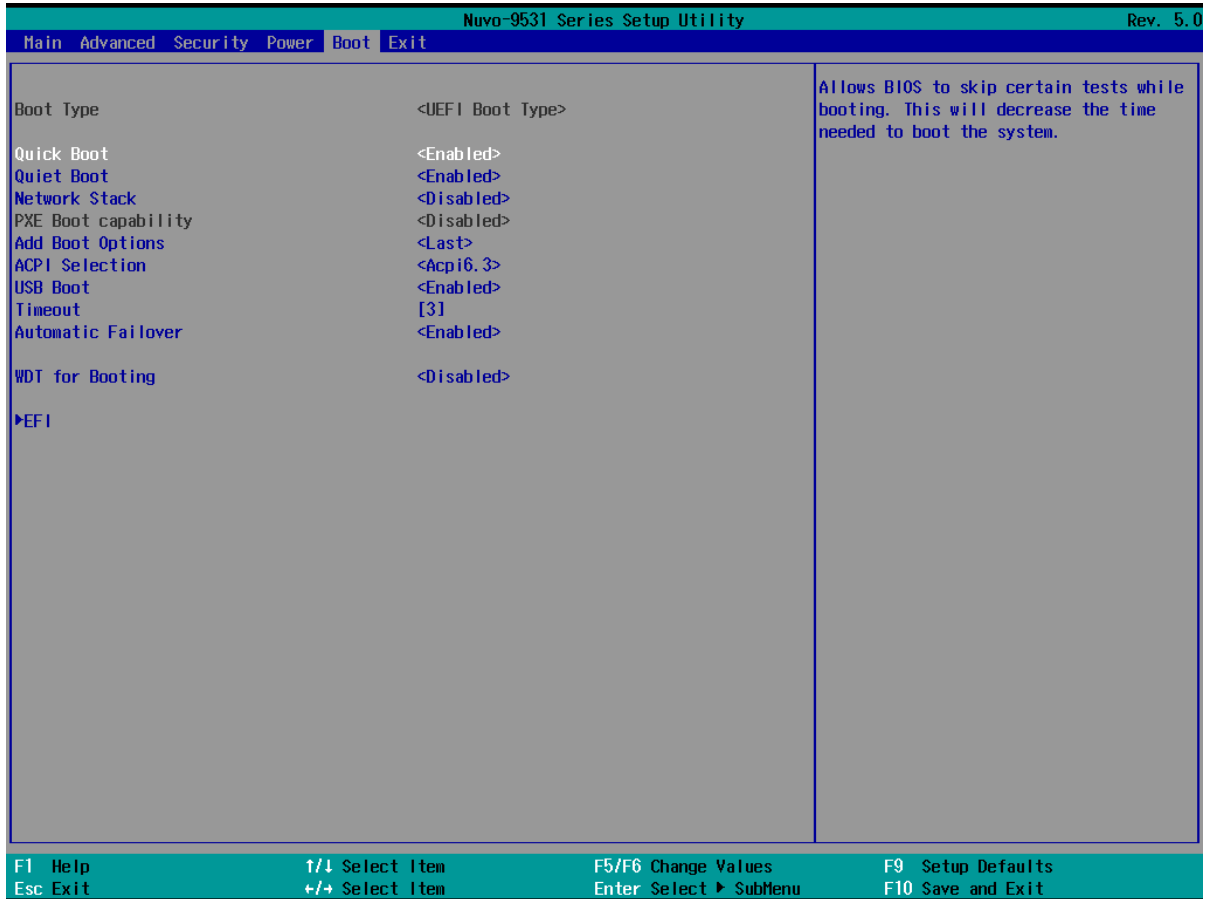

Value	Option	Description
Boot Type	UEFI Boot Type	Only UEFI boot media listed are approved as boot media.
Quick Boot	Enabled	The system starts up faster because BIOS skips various hardware function tests
	Disabled	The system starts up slower because BIOS goes through various hardware functions tests
Network Stack	Enabled	The system is available for network access using UEFI.
	Disabled	The system is not available for network access using UEFI.
PXE Boot	Disabled	Only UEFI Network Stack is supported: Preboot

capability		eXecution Environment (PXE) is not supported
	Enabled	By enabling the PXE boot, one can choose to boot via I219 Only/ I225 Only or All NICs .
Add Boot Options	First	Newly detected boot media are placed at the top of the boot order.
	Last	Newly detected boot media are placed at the bottom of the boot order.
ACPI Selection	1.0B/ 3.0/ 4.0/ 5.0/ 6..3	Advanced Configuration and Power Interface allows the operating system to control system power management
USB Boot	Enabled	Allow boot from bootable USB devices.
	Disabled	Does not allow boot from bootable USB devices
Timeout	1, 2, 3, etc (in seconds)	Boot delay time in seconds to give the user time to activate the hotkey to access the BIOS
Automatic Failover	Enabled	Automatically checks for the next bootable device when the set default device fails.
	Disabled	Will only boot from the designated device.
WDT for booting	Disabled, 1, 3, 5, 10 (minutes)	WDT ensures a successful system boot by specifying a timeout value
EFI	NA	Extensible Firmware Interface

4.1.11 Add Boot Options (Position New Boot Device)

The Add Boot Options dedicates the boot sequence order of a newly added device (eg. USB flash drive). The setting allows you to set the newly added device to boot first or as the last device on the list.

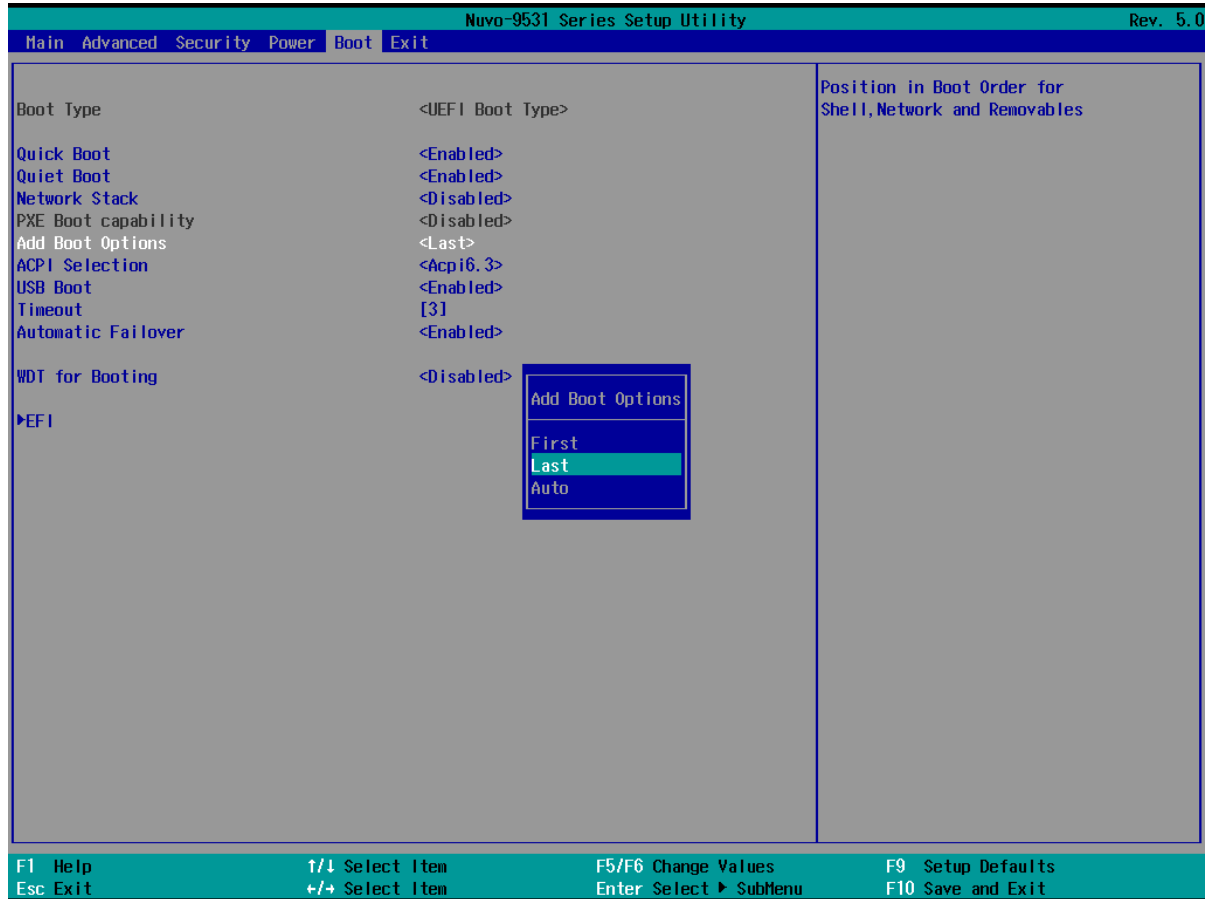

To set Add Boot Options:

1. When system boots up, press F2 to enter BIOS setup utility.
2. Go to **[Boot]** > **[Add Boot Options]**, press Enter to bring up options, First or Last.
3. Highlight your selection, **[First]** or **[Last]**, and press Enter, press F10 to “Exit Saving Changes”.

4.1.12 Watchdog Timer for Booting

The Watchdog timer setting in the BIOS ensures a successful system boot by specifying a timeout value. If the Watchdog timer is not stopped and expires, the BIOS will issues a reset command to initiate another boot process. There are two options in BIOS menu, “**Automatically after POST**” and “**Manually after Entering OS**”. When “**Automatically after POST**” is selected, the BIOS automatically stop the watchdog timer after POST (Power-On Self Test) OK. When “**Manually after Entering OS**” is selected, it’s user’s liability to stop the watchdog timer when entering OS. This guarantees the system can always boot into OS, otherwise another booting process will be initiated.

For information about programming watchdog timer, please refer to **Appendix A Watchdog Timer & Isolated DIO**.

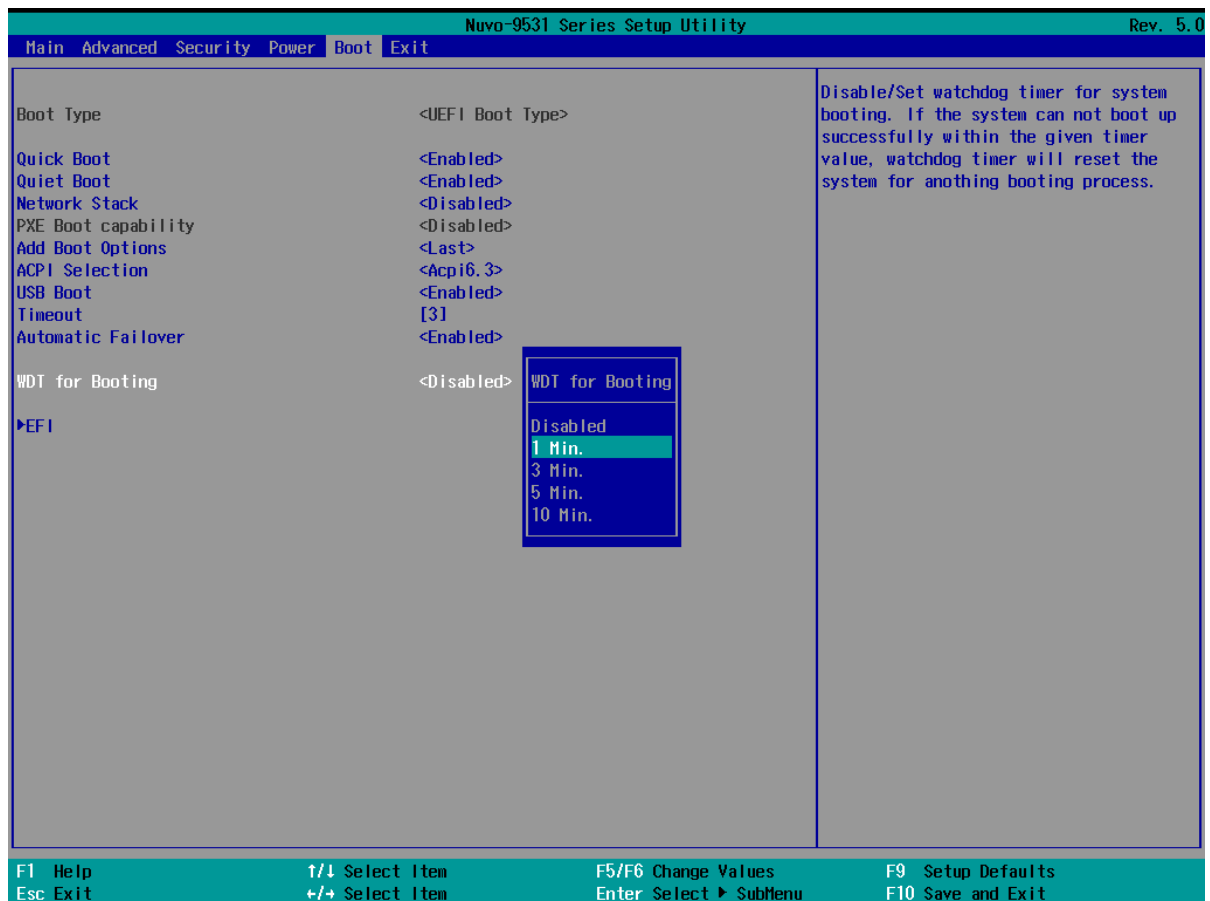

To set the watchdog timer for boot in BIOS:

1. When system boots up, press F2 to enter BIOS setup utility.
2. Go to **[Boot]** menu.
3. Disable or select timeout value for **[WDT for Booting]** option.
4. Once you give a timeout value, the **[WDT Stop Option]** option appears. You can select “*Automatically after POST*” or “*Manually after Entering OS*”.
5. Press F10 to “Exit Saving Changes.

5 OS Support and Driver Installation

5.1 Operating System Compatibility

The system supports most operating system developed for Intel® x86 architecture. The following list contains the operating systems which have been tested by Neosys Technology.

- Microsoft Window 10 LTSC 2021 (x64)
- Ubuntu 20.04.5 LTS, 22.04 LTS, 22.04.1 LTS or other distribution with kernel version \geq 5.15 */**



NOTE

**For Linux system, user may need to manually compile and install the driver for Intel graphics or I226 GbE controller if the driver is not embedded in kernel. You can visit Intel website for further information.*

***For distributions, graphics driver may not be completely implemented in its kernel. You may encounter restrictions when using these features, such as dual independent display. For optimum operation, it is the users' responsibility to manually check for new drivers and upgrades!*

Neosys may remove or update operating system compatibility without prior notice. Please contact us if your operating system of choice is not on the list.

5.2 Driver Installation

The system drivers are available online, please click on this [link](#) to download the drivers.

5.2.1 Install Drivers Automatically

Neosys provides a driver package which contain function APIs for Watchdog Timer control function. You should install the driver package (WDT_DIO_Setup.exe) in prior to use these functions. Please note that you must install WDT_DIO_Setup_v2.3.2.0 or later versions.

Please refer to this [link](#) to download WDT_DIO.

Appendix A Using WDT & DIO

Watchdog Timer

The watchdog timer (WDT) function ensures reliable system operation. The WDT is a hardware mechanism to reset the system if the watchdog timer expires. Users can start the WDT and keep resetting the timer to make sure the system or program is running. Otherwise, the system shall be reset.

In this section, we'll illustrate how to use the function library provided by Neosys to program the WDT functions. Currently, WDT driver library supports Windows 10 64-bit versions. For other OS support, please contact Neosys Technology for further information.

Installing WDT_DIO Library

The WDT_DIO function library is delivered in the form of a setup package named **WDT_DIO_Setup.exe**. Prior to programming WDT, you should execute the setup program and install the WDT library. Please use the following WDT_DIO_Setup packages according to your operating systems and application.

- For Windows 10 64-bit OS with 64-bit application (x64 mode), please install WDT_DIO_Setup_v2.3.2.0 (x64).exe or later version.
- For Windows 10 64-bit OS with 32-bit application (WOW64 mode), please install WDT_DIO_Setup_v2.3.2.0 (wow64).exe or later version.

WDT and DIO Library Installation

To setup WDT & DIO Library, please follow instructions below.

1. Execute **WDT_DIO_Setup.2.3.2.0.exe**. and the following dialog appears.

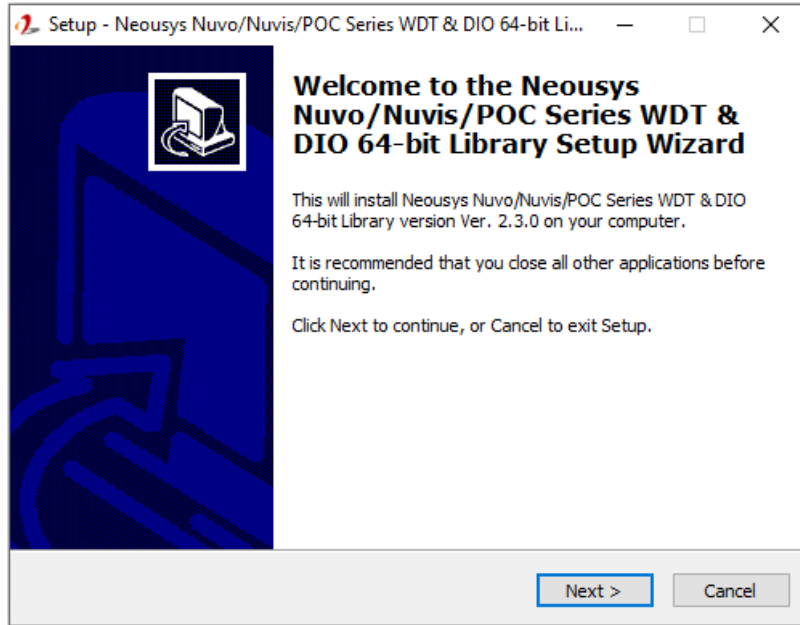

2. Click “Next >” and specify the directory of installing related files. The default directory is *C:\Neosys\WDT_DIO*.

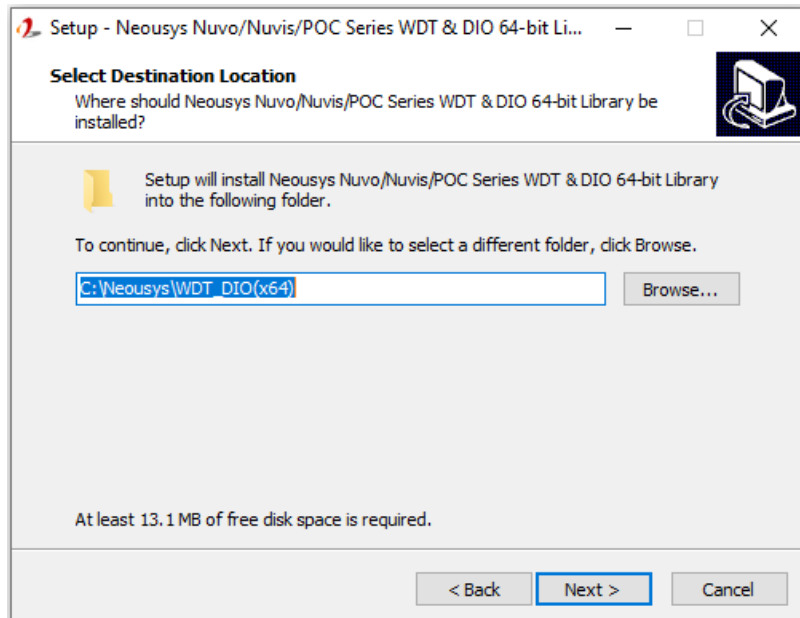

- Once the installation has finished, a dialog will appear to prompt you to reboot the system. The WDT & DIO library will take effect after the system has rebooted.

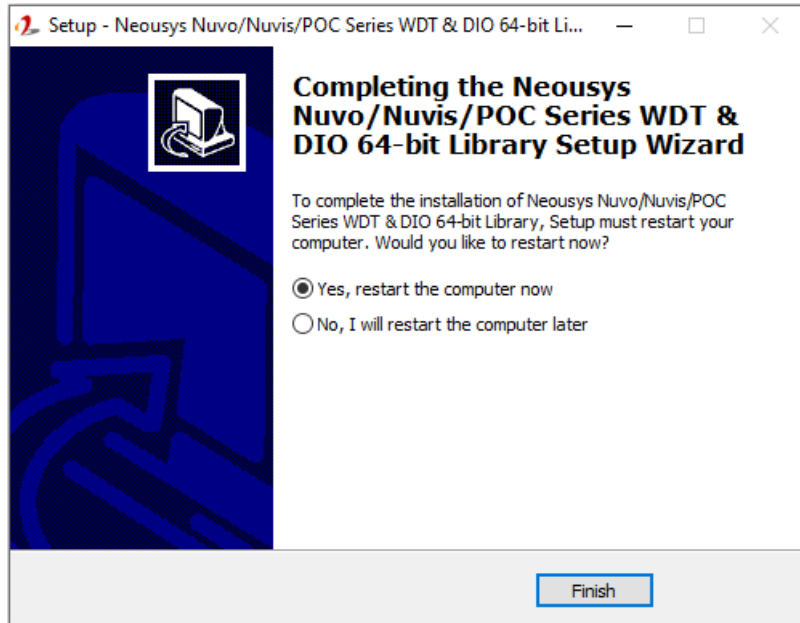

- When programming your WDT or DIO program, the related files are located in

Header File:	\Include
Library File:	\Lib
Function	\Manual
Reference:	
Sample Code:	\Sample\ WDT_Demo (Demo for Watchdog Timer) \Sample\ DIO_Demo (Demo for Polling I/O)

WDT Functions

InitWDT

Syntax	BOOL InitWDT(void);
Description:	Initialize the WDT function. You should always invoke InitWDT() before set or start watchdog timer.
Parameter	None
Return Value	TRUE: Successfully initialized FALSE: Failed to initialize
Usage	BOOL bRet = InitWDT()

SetWDT

Syntax	BOOL SetWDT(WORD tick, BYTE unit);
Description	Set timeout value and unit for watchdog timer. When InitWDT() is invoked, a default timeout value of 255 seconds is assigned.
Parameter	tick WORD value (1 ~ 65535) to indicate timeout ticks. unit BYTE value (0 or 1) to indicate unit of timeout ticks. 0 : unit is minute 1: unit is second
Return Value	If value of unit is correct (0 or 1), this function returns TRUE, otherwise FALSE.
Usage	WORD tick=255; BYTE unit=1; //unit is second. BOOL bRet = SetWDT(tick, unit); //timeout value is 255 seconds

StartWDT

Syntax	BOOL StartWDT(void);
Description	Starts WDT countdown. Once started, the WDT LED indicator will begin blinking. If ResetWDT() or StopWDT is not invoked before WDT countdowns to 0, the WDT expires and the system resets.
Parameter	None
Return Value	If the timeout value is given in correct format (WDT started), this function returns TRUE, otherwise FALSE
Usage	BOOL bRet = StartWDT()

ResetWDT

Syntax	BOOL ResetWDT(void);
Description	Reset the timeout value to the value given by SetWDT().If ResetWDT() or StopWDT is not invoked before WDT countdowns to 0, the WDT expires and the system resets.
Parameter	None
Return Value	Always returns TRUE
Usage	BOOL bRet = ResetWDT()

StopWDT

Syntax	BOOL StopWDT(void);
Description	Stops the countdown of WDT. When WDT has stopped, the WDT LED indicator stops blinking.
Parameter	None
Return Value	Always returns TRUE
Usage	BOOL bRet = StopWDT()

DIO Functions

InitDIO

Syntax	BOOL InitDIO(void);
Description	Initialize the DIO function. You should always invoke InitDIO() before write/read any DIO port/channel.
Parameter	None
Return Value	Returns TRUE if initialization successes, FALSE if initialization failed.
Usage	BOOL bRet = InitWDT();

DIReadLine

Syntax	BOOL DIReadLine(BYTE ch);
Description	Read a single channel of isolated digital input.
Parameter	ch BYTE value specifies the DI channel to be read. <i>Ch</i> should be a value of 0 ~ 7.
Return Value	The status (TRUE or FALSE) of the specified DI channel.
Usage	BYTE ch=3; //DI channel #3 BOOL DIChValue = DIReadLine(ch); //read DI channel #3

DIReadPort

Syntax	WORD DIReadPort(void);
Description	Read the entire isolated digital input port (8 channels).
Parameter	None
Return Value	A WORD value (0~255) indicates the status of DI port (8 DI channels).
Usage	WORD DIPortValue = DIReadPort ();

DOWriteLine

Syntax	void DOWriteLine(BYTE ch, BOOL value);
Description	Write a single channel of isolated digital output.
Parameter	<p>ch BYTE value specifies the DO channel to be written. <i>Ch</i> should be a value of 0 ~ 7.</p> <p>value BOOL value (TRUE or FALSE) specifies the status of DO channel.</p>
Return Value	None
Usage	<pre> BYTE ch=3; //DI channel #3 BOOL DOChValue=TRUE; DOWriteLine(ch, DOChValue); //write DO channel #3 as TRUE </pre>

DOWritePort

Syntax	void DOWritePort(WORD value);
Description	Write the entire isolated digital output port (8 channels).
Parameter	<p>value WORD value specifies the status of the DO port. <i>Value</i> should be a value of 0~255.</p>
Return Value	None
Usage	<pre> WORD DOPortValue=0XFF; //11111111b DOWritePort(DOPortValue); //write DO port as 11111111b </pre>

Appendix B PoE On/ Off Control

The system offers optional 802.3at PoE+ ports and users are allowed to manually turn on or off the power supply of each PoE port. This can be useful in power device (PD) fault-recovery or power reset. The APIs are part of Neosys WDT_DIO driver package. Please follow the instructions in [Appendix A Watchdog Timer & Isolated DIO](#) for installation before programming PoE on/off control function.

GetStatusPoEPort

Syntax	BYTE GetStatusPoEPort (Byte port);
Description	Get current on/off status of designated PoE port.
Parameter	<i>port</i> BYTE value specifies the index of PoE port. Please refer to the following illustration, <i>port</i> should be a value of 1 ~ 4
Return Value	BYTE value indicating PoE on/off status 0 if port is disabled (off) 1 if port is enabled (on)
Usage	BYTE bEnabled = GetStatusPoEPort (1); //Get on/off status of PoE Port#1

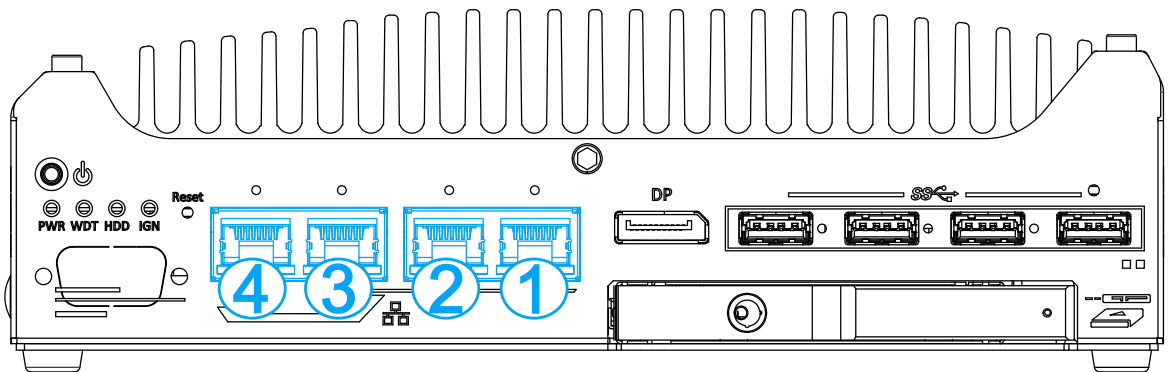

PoE+ ports on the front panel

EnablePoEPort

Syntax	BOOL EnablePoEPort (BYTE port);
Description	Turn on PoE power of designated PoE port.
Parameter	<i>port</i> BYTE value specifies the index of PoE port. Please refer to the following illustration, <i>port</i> should be a value of 1 ~ 4
Return Value	TRUE if enabled success FALSE if fail to enable.
Usage	BOOL bRet = EnablePoEPort (1); //Turn on PoE Port#1

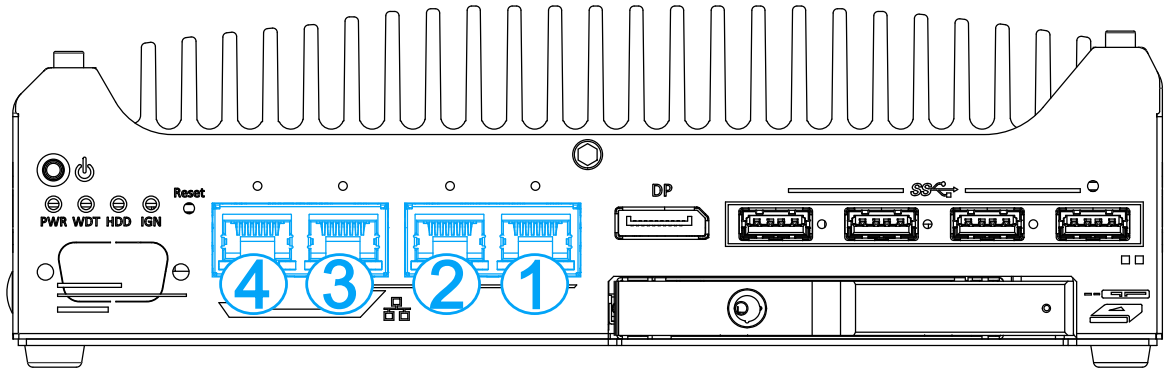

PoE+ ports on the front panel

DisablePoEPort

Syntax	BOOL DisablePoEPort (BYTE port);
Description	Turn off PoE power of designated PoE port
Parameter	<i>port</i> BYTE value specifies the index of PoE port. Please refer to the following illustration, <i>port</i> should be a value of 1 ~ 4
Return Value	TRUE if disabled success FALSE if fail to disable
Usage	BOOL bRet = DisablePoEPort (1); //Turn off PoE Port#1

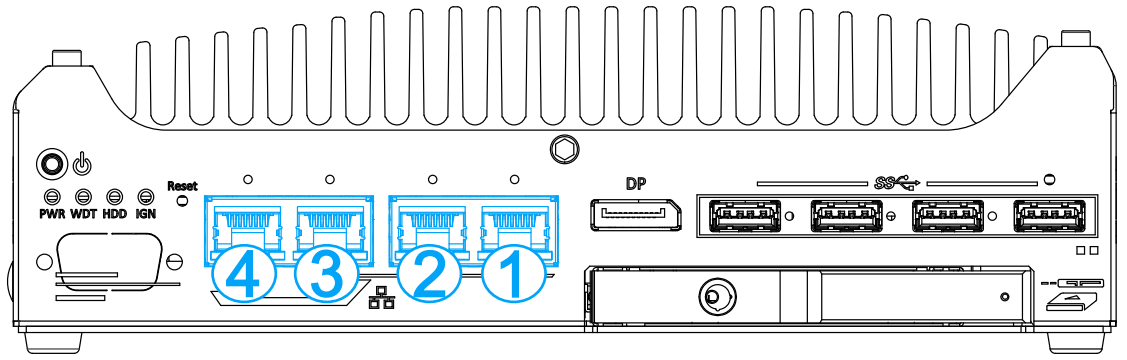

PoE+ ports on the front panel